

# FBX

Gas insulated switchgear up to 24 kV





---

Presentation 3

---

FBX range 9

---

Use 15

---

Characteristics 23

---

Protection, Monitoring & Control 33

---

Accessories and options 41

---

Installation 47

---

Schneider Electric Services 63

---

The environment 67



---

<b>Introduction</b>	<b>4</b>
<b>Standards &amp; quality</b>	<b>5</b>
<b>Product description</b>	<b>6</b>
<b>Schneider Electric Services</b>	<b>8</b>

PE8600



Example of FBX-Extensible in industry

## FBX, a versatile switchboard

FBX is a medium voltage switchboard up to 24 kV, 630/1250 A, 25 kA 1s, used in secondary distribution applications. It can be fitted with the following protection devices:

- Transformer protection by fuse (T1 function)
- Transformer protection by vacuum circuit-breaker (T2 function)
- Protection by O-C-O vacuum circuit-breaker (CB or CBb function).

Its compactness, wide range of functions and ease of installation and extensibility, make it a versatile switchboard to fit many secondary distribution applications such as: public distribution, industry, infrastructure or renewables.

## Electrically insulated using SF6 gas

The high voltage conductive parts of the FBX switchboard are placed in an insulating inert gas (Sulphur Hexafluoride - SF6) which is neither reactive nor toxic.

The gas is confined in a hermetically sealed stainless steel tank. FBX is insensitive to the outside environment and to any possible aggressions such as:

- Humidity
- Dust
- Pollution
- Dirt
- Harmful rodents.

The use of SF6 as an insulating gas, and the design of FBX, makes it one of the most compact MV switchboards on the market (for instance, a cubicle with 3 functional units is 1 metre wide).

## Easy to install

The installation of FBX is very easy whatever its installation location. Its functional units are ultra compact thanks to the technology of current interruption in SF6 gas, and their footprint on the floor is minimized.

FBX-E, the extensible version of FBX, can be assembled into a complete switchboard, functional unit by functional unit, with narrow installation access. For instance, for an installation underground or on upper floors, or in wind towers.

PE8604



FBX-C in a MV/LV substation – chosen for its compact size

## Simple operation and maintenance

With a service life of 30 years for the main circuit without maintenance, the overall design of the range of FBX switchboards guarantees simple and reliable use:

- Simplified maintenance of the functional units and with continuity of service for the other units (LSC2 class)
- No gas filling is required on site at installation nor during the service life of FBX under normal operating conditions
- Long service life
- Interlocking to ensure the correct sequences of operations
- Can be used in substations with or without walk-in operation corridors
- Voltage presence indicator light
- Wide cable compartment to allow the installation of various types of cable, etc.

## Safety and innovation

FBX has been designed for maximum safety of the operators and equipment in particular in case of internal arcing in the equipment:

- Safety valves at the rear yield and thus avoid gas overpressure
- An exhaust duct cools down and evacuates the gases towards the top (optional) and/or a deflector at the rear channels and cools the hot gases
- Front protection for the operator (lateral also as an option).

PE8649



FBX-E in the mast of a wind tower, can be installed through a narrow door thanks to its compact size

## Conformity with standards in force

FBX meets the current national or international standards in force: (IEC, NF, CNS, IS).

The main electro-technical standards cover:

- The design of the functional units and switchgear
- Medium voltage switchgear (interruption, sectionalizing, insulation)
- Current and voltage transformers
- Low voltage switchgear
- SF6 gas
- Cables and conductors
- Graphs and diagrams
- Tests
- International electro-technical vocabulary.

## A quality and safety approach

The Mâcon site, in France, has, for many years, been committed to a global quality approach and is certified:

- ISO 9001: 2000
- ISO 14001: 2004
- OHSAS 18001 (since 1999).

## Tests on the devices

Various factory tests are carried out on FBX before it is shipped to the customer:

- Tank leak-tightness test
- Mechanical test for control mechanisms
- Dielectric tests
- Electrical tests.



SF6 leak test

The FBX switchboards comply with the requirements of the following standards and regulations:

Description	IEC standard	IEC classes	EN standard
Switchboard	IEC 62271-200 IEC 62271-1		EN 62271-200 EN 62271-1
Behaviour in the event of internal faults	IEC 62271-200		EN 62271-200
Earthing switch (in C, T1, T2, RE, CB, CBb)	IEC 62271-102	E2	EN 62271-102
Disconnecter (in T2, CB, CBb)	IEC 62271-102	M0	EN 62271-102
General use switch (C)	IEC 62271-103	M1, E3, C1	
Switch-disconnector fuse combination (T1)	IEC 62271-105	M1, E1	
Circuit-breaker (in T2, CB, CBb)	IEC 62271-100	M1, M2, E2	EN 62271-100
Current transformer	IEC 60044-1		EN 60044-1
Voltage transformer	IEC 60044-2		EN 60044-2
Voltage presence indicators	IEC 61958		EN 61958
Voltage detection systems	IEC 61243-5		EN 61243-5
Protection against accidental contact, foreign bodies and ingress of water	IEC 60529		EN 60529 1
Installation			HD 637 S
Operation of the electrical equipment			EN 50110

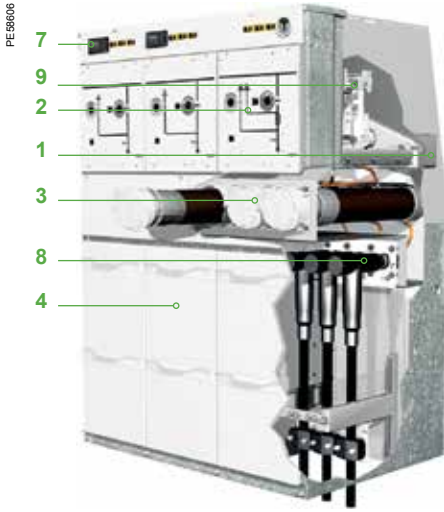

Illustration of an FBX-C  
C-C-T1 function, protection by fuses

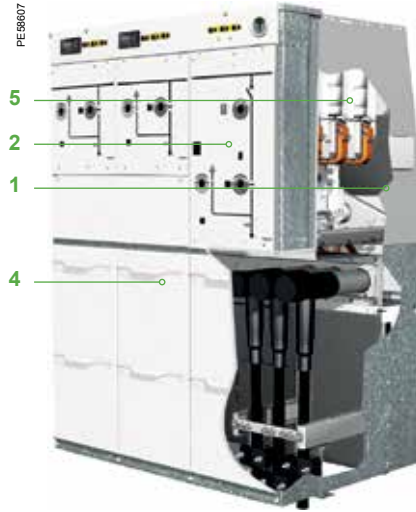

Illustration of an FBX-C  
C-C-T2 function, protection by vacuum circuit-breaker

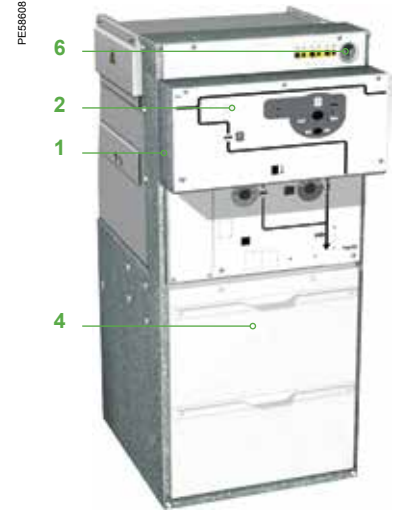
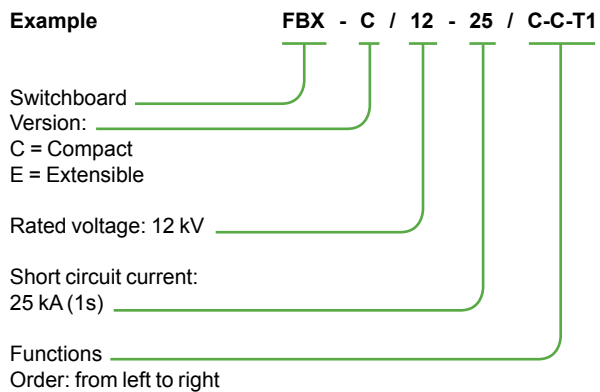

Illustration of an FBX-E  
Vacuum circuit-breaker function

- 1 Hermetically-sealed stainless steel tank filled with gas to insulate the main circuit
- 2 Operating mechanism compartment and mimic diagram
- 3 Fuse compartment
- 4 Cables compartment door
- 5 Vacuum circuit-breaker
- 6 Tank pressure manometer
- 7 Voltage presence detection system and low voltage part
- 8 Cable plug-in connections
- 9 3-position switch-disconnector

**Identification plate**

The rating plate supplies information on the version, the short time rated current, rated voltage and components.





### Reduction of the current assigned in continuous service according to the maximum ambient temperature

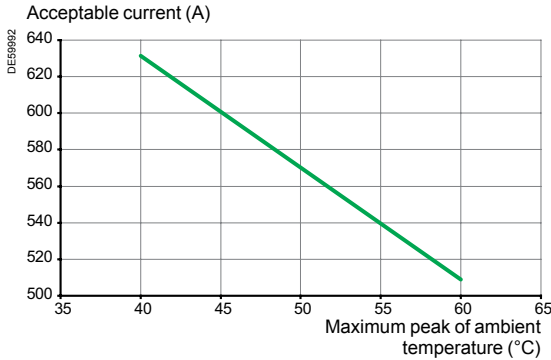

## Operating conditions

- Temperature classification: -5°C indoors (option: -25°C).
- Ambient temperature: from -5°C to +40°C (option: -25°C) (option: up to +55°C for reduced service currents)
- Average value over 24 hours (max.): +35°C
- Typical maximum altitude for installation above sea level is 1,000 m. However, much higher altitudes are possible on request but with limitations when Metering or HV fuse-holders functions are requested.
- Type of insulating gas: sulphur hexafluoride (SF6)
- Rated pressure at +20°C: 0.03 MPa
- Flood proof (option): successfully tested under water for 24 hours at 24 kV 50 Hz.

## Protection index (IP)

- Main electrical circuits: IP67
- Fuse compartment: IP65 (option: IP67)
- Operating mechanisms: IP2X (option: IP33)
- Cable connection compartment: IP2XC
- Busbar: 1250 A on top of unit: IP67
- Switchgear: IK07.

## Partition class and loss of service continuity category

- Partition Class: PM<sup>(1)</sup>
- Loss of Service Continuity Category: LSC2<sup>(2)</sup>

## Internal Arc Classification

FBX is a pressurized sealed-unit system that complies with IEC 62271-1. Its tank is filled with SF6 gas that is used as an insulating and breaking medium. FBX internal arc classification as per IEC 62271-200 is detailed in the table below. In the unlikely event of gas overpressure, the gas is discharged via safety valves away from the operator.

Rated voltage	Functions	
Internal arc withstand	C - T1 - T2 - R - RE -CB - CBb	AFL 16 kA 1 s AFL 20 kA 1 s AFL 25 kA 1 s <sup>(3)</sup>
	M1 - M2 - M3 - M4 <sup>(4)</sup>	AF 16 kA 1 s AF 20 kA 1 s

(1) PM class according to IEC 62271-200 edition 2: metallic partitioning between compartments.  
 (2) Based on IEC62271-200 edition 2, FBX is now classified as LSC2 apart from the functions (R, RE & M) which are LSC1.  
 (3) With exhaust towards the bottom. Nkt cable required for two cables per phase fitting.  
 (4) Can be considered "AFL" if surrounded on both sides by AFL FBX functions.



---

<b>Introduction</b>	<b>10</b>
<b>Range of functions</b>	<b>11</b>
<b>Available configuration</b>	<b>13</b>
<b>Overall dimensions</b>	<b>14</b>

## FBX-C: compact version

This version can be easily integrated into a substation thanks to its compact size and small footprint. Up to 5 functional units can be assembled in a single tank insulated by SF6 gas.

## FBX-E: extensible version

The extensible version of FBX, FBX-E, is used to enable the extension of a switchboard with additional functional unit.



### ■ **FBX-DE:** Double Extensible version

FBX switchboard can be extended on either or both left and right sides.

### ■ **FBX-SE:** Single Extensible version

FBX switchboard can only be extended on the right side.

These versions offer the following advantages:

- A highly economic solution for secondary distribution applications
- Installation in very limited space locations such as through a narrow opening or hatch is possible
- The additional FBX-E functional units can be arranged in any order you like
- A subsequent extension is possible:
  - either with an extensible FBX-E functional unit connected with the A-link device at the bushing level
  - or via a 1250 A top busbar on the roof connecting FBX-E functional unit at busbar level.
- The flexibility and modularity of FBX-E make FBX an ideal MV switchboard for applications in the industrial sector, or for those liable to change in time such as public distribution network.

## Main functional units:

- C** Cable incoming or outgoing feeder with switch-disconnector and earthing switch
- T1** Transformer protection with switch-disconnector fuse combination
- T2** Transformer protection with vacuum circuit-breaker
- R** Direct incoming feeder without earthing switch
- RE** Direct incoming feeder with earthing switch
- Sb** Busbar switch-disconnector
- CB** Outgoing feeder protection with vacuum circuit-breaker
- CBb** Busbar protection with vacuum circuit-breaker
- M** Metering functional unit

## Main functional units

Names	C	T1	T2	R	RE	Sb	CB	CBb	M
Functions	Cable incoming or outgoing feeder with switch-disconnector	Transformer protection with switch-disconnector fuse combination	Transformer protection with vacuum circuit-breaker	Direct incoming feeder without earthing switch	Direct incoming feeder with earthing switch	Busbar switch-disconnector	Outgoing feeder protection with vacuum circuit-breaker	Busbar protection with vacuum circuit-breaker	Metering
Single line diagrams									

### C function

- The interrupting mechanisms are located in the sealed-for-life tank filled with gas.
- The three-position switch is equipped with a spring-loaded closing mechanism for the switch-disconnector function and the earthing switch function.

### T1 function

- To make the replacement of HV fuses secure, earthing switches are placed both upstream and downstream from the fuses.
- Both earthing switches are connected mechanically and are activated with a single operating mechanism.
- The switch-disconnector is equipped with a spring-loaded mechanism for the closing operations and a stored energy mechanism for breaking operations which is mechanically pre-loaded.
- When the striker pin trips on the blowing of one of the HV fuses, the switch-disconnector is opened mechanically on all three phases.
- An indicator on the front panel of the FBX visually signals the interruption due to a fuse blowing.
- A pushbutton for tripping the opening of the switch is available as an option.
- An opening by tripping coil is also possible.
- The earthing function is operated with a separate spring mechanism.

### T2 function

- The transformer outgoing feeder with vacuum circuit-breaker can be used for applications where the load current is too high for the use of a switch-disconnector fuse combination.
- A typical application is the protection of distribution transformers and wind farm installations up to 21 MVA.
- The T2 three-phase transformer protection comprises a vacuum circuit-breaker (located upstream) and a 3-position disconnector carrying out the sectionalizing of the line.
- The disconnector and earthing switch with making capacity are activated by a spring-loaded mechanism.
- The vacuum circuit-breaker is equipped with an energy accumulation spring-loaded mechanism.
- The operating sequence in case of the use of a motorized mechanism is the following: O – 3 min. – CO.
- The vacuum circuit-breaker can be tripped manually by a pushbutton or automatically by a motorized mechanism controlled by a DPX-1 protection relay (standard equipment – other relays available on request). The latter analyses the metering data captured by the current transformers on each phase and is triggered at pre-defined threshold levels.
- Fault trips require no auxiliary voltage if an autonomous relay is used.

### R function

- This function allows for the direct connection of a cable incoming feeder to the busbar of the FBX switchboard.

### RE function

- This function, which is equipped with an earthing switch, allows for the direct connection of a cable incoming feeder to the busbar of the FBX switchboard.

## Sb function

- This function is used for the opening and disconnection of the busbar to separate the end-user from the energy provider.

## CB function

- The CB function includes a vacuum circuit-breaker and a three-position disconnecter switch.
- Fast auto-reclosing operating cycle: O - 0.3 s - CO - 15 s - CO.
- The earthing switch with making capacity is activated by a spring-loaded mechanism.
- The vacuum circuit-breaker is equipped with a double-latch energy accumulation spring-loaded mechanism and can be pre-loaded manually or electrically for a complete OCO cycle.
- An integrated protection relay is linked to the circuit-breaker.
- One of the following two autonomous relays can be integrated behind the front cover with the current transformers fitted on cable plug-in connections: DPX-1 and WIC.
- Other non-autonomous relays can be used by fitting a low voltage cabinet with the current transformers fitted either to the withdrawable terminals or onto the outgoing feeder cables.
- In option: metering with current transformers fitted to the cables in the cubicle's compartment.
- When connected to an overhead line network, the CB function can protect from temporary line faults. It can also provide private network protection.

## CBb function

- The CBb function is used to protect the switchgear busbar (on the left or right-hand side). Example of use: medium voltage metering switchboard.
- This function uses the same vacuum circuit breaker and mechanism as the CB function.

## M function

- This function allows for metering of electricity consumption thanks to its current and voltage transformers.
- To fit all possible configurations, four metering panel versions exist with different busbar positions. In the M1 to M4 versions, the current and voltage transformers can be switched between each other.
- Options:
  - Flooring for M1, M2 and M3 with a rubber grommet for the passage of the cables.
  - Flooring completely closed, but with overpressure escape devices.

### For 12 kV and 24 kV

M1 Version

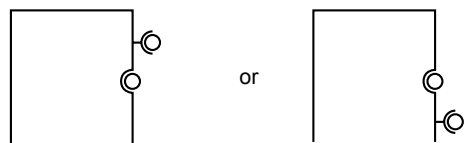

M2 Version

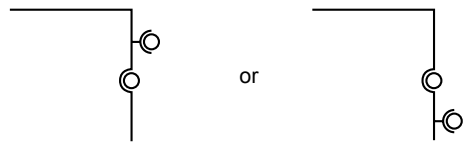

M3 Version

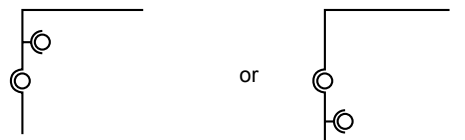

M4 Version

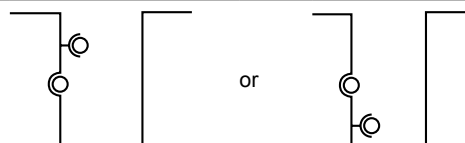

## FBX-C, compact version (non extendable)

2 functions

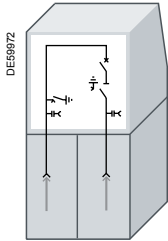

Versions

C	C
C	T1
C	T2
RE	T1
RE	T2

3 functions

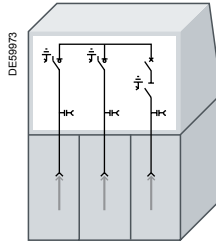

Versions

C	C	C
C	C	T1
C	C	T2
C	RE	T1
C	RE	T2
R	RE	T1
R	RE	T2

4 functions

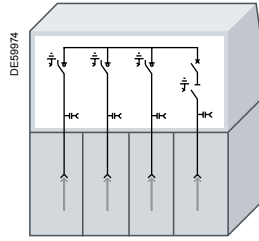

Versions

C	C	C	C
C	C	C	T1
C	C	C	T2
C	T1	C	T1
C	T2	C	T2

5 functions

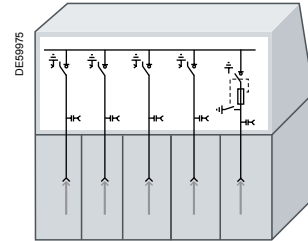

Versions

C	C	C	C	C
C	C	C	C	T1
C	C	T1	C	T1
C	T1	C	T1	T1

## FBX-E, extendable version

**FBX-DE:** Double Extensible version

FBX switchboard can be extended on either or both left and right sides.

**FBX-SE:** Single Extensible version

FBX switchboard can only be extended on the right side.



1 function

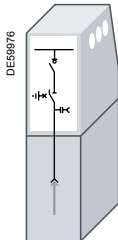

Versions

C
R
RE

1 function

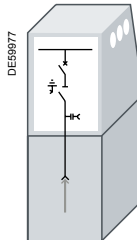

Versions

T1
T2

1 function

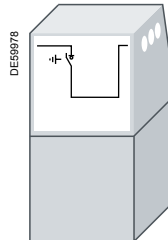

Version

Sb
----

1 function

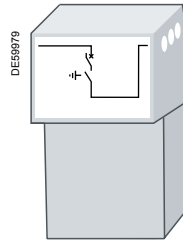

Version

CBb
-----

1 function

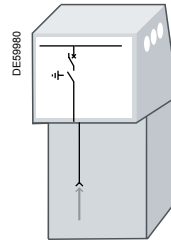

Version

CB
----

2 functions

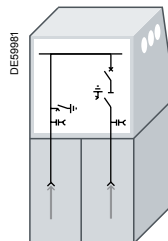

Versions

C	C
C	T1
C	T2
T1	T1
T2	T2
RE	T1
RE	T2

3 functions

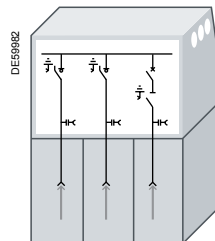

Versions

C	C	C
C	C	T1
C	C	T2
C	RE	T1
C	RE	T2
R	RE	T1
R	RE	T2

4 functions

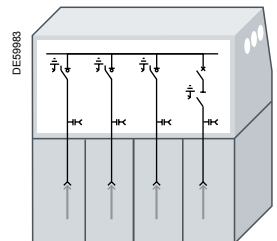

Versions

C	C	C	C
C	C	C	T1
C	C	C	T2
C	T1	C	T1
C	T2	C	T2

## Dimensions and weights of the FBX-C

Function	Number of functional units	Height (mm)	Depth (mm)	Width (mm)	Approximative weight (kg)			
C-C	2	1380 (option 1040)	752	680	200			
C-T1		1380 (option 1040)			200			
C-T2		1380			240			
RE-T1		1380 (option 1040)			210			
RE-T2		1380			240			
C-C-C		3			1380 (option 1040)	752	1000	320
C-C-T1	1380 (option 1040)		330					
C-C-T2	1380		360					
C-RE-T1	1380 (option 1040)		320					
C-RE-T2	1380		360					
R-RE-T1	1380 (option 1040)		320					
R-RE-T2	1380		350					
C-C-C-C	4		1380 (option 1040)	752	1320			440
C-C-C-T1			1380 (option 1040)					450
C-C-C-T2			1380					480
C-T1-C-T1		1380 (option 1040)	470					
C-T2-C-T2		1380	530					
C-C-C-C-C		5	1380 (option 1040)			752	1685	550
C-C-C-C-T1	1380 (option 1040)		550					
C-C-T1-C-T1	1380 (option 1040)		550					
C-T1-C-T1-T1	1380 (option 1040)		1805	570				

## Dimensions and weights of the FBX-E

Function	Number of functional units	Height (1) (mm)	Depth (mm)	Width (2) (3) (mm)	Approximative weight (kg)		
M1	1	1380	720	1000	490		
M2		1380		1005	490		
M3		1380		490			
M4		1380		1010	490		
C	1	1380 (option 1040)	752	360	135		
R		1380 (option 1040)			125		
RE		1380 (option 1040)			135		
T1		1380 (option 1040)			490	160	
T2		1380		190			
CB		1380		873	490	220	
CBb		1380		625	250		
Sb		1380		752	680	200	
C-C		2		1380 (option 1040)	752	680	210
C-T1				1380 (option 1040)			210
C-T2	1380		240				
T1-T1	1380		1000	310			
T2-T2	1380		370				
RE-T1	1380 (option 1040)		680	220			
RE-T2	1380		250				
C-C-C	3		1380 (option 1040)	752		1000	330
C-C-T1			1380 (option 1040)				340
C-C-T2			1380				370
C-RE-T1		1380 (option 1040)	330				
C-RE-T2		1380	360				
R-RE-T1		1380 (option 1040)	330				
R-RE-T2		1380	360				
C-C-C-C		4	1380 (option 1040)		752		1320
C-C-C-T1	1380 (option 1040)		460				
C-C-C-T2	1380		490				
C-T1-C-T1	1380 (option 1040)		480				
C-T2-C-T2	1380	510					

(1) With a 1250 A busbar on the top, add 217 mm.

(2) Add 17.5 mm for the busbar protective covers (right or left) at the extremity of the switchboard.

(3) To calculate the total width of several connected FBX-E switchboards, add 9 mm between each extension.







---

<b>User interface</b>	<b>18</b>
<b>Interlocks</b>	<b>20</b>
<b>Extensibility</b>	<b>21</b>
<b>Cable compartment</b>	<b>22</b>
<b>Fuse compartment</b>	<b>23</b>

## User interface description

Thanks to its clear mimic diagram, the user interface makes it easy and safe to operate FBX.

Each switching device is equipped with an access point for the control lever and an indicator of the mechanical position.

The two earthing switches, both upstream and downstream from the MV fuse holders on the T1 switch-disconnector fuse combination, are activated simultaneously by a common mechanism.

The switch-disconnectors and vacuum circuit-breakers can be equipped, as an option, by a motorised control mechanism. In this case, a mechanical back-up crank handle is provided.

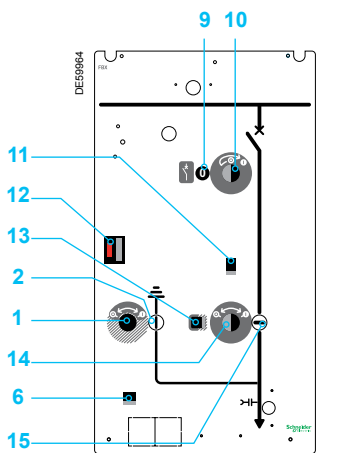

Transformer protection with vacuum circuit-breaker T2

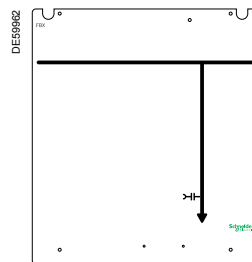

Direct incoming feeder without earthing switch (R)

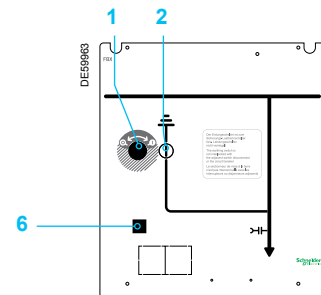

Direct incoming feeder with earthing switch (RE)

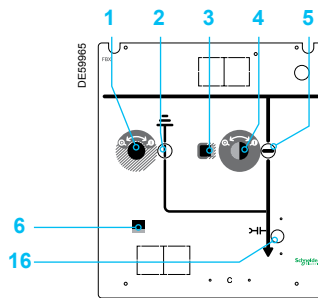

Incoming/outgoing feeder with switch-disconnector (C)

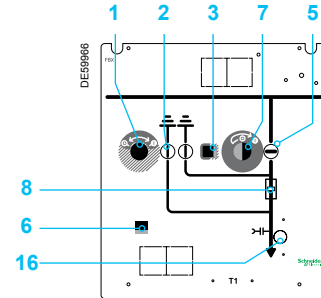

Outgoing feeder with T1 switch-disconnector fuse combination

- 1 Lever hub socket for the earthing switch
- 2 Earthing switch position indicator
- 3 Interlocking between the switch-disconnector and earthing switch
- 4 Lever hub socket for the switch-disconnector
- 5 Switch-disconnector position indicator
- 6 Interlocking between the cable compartment door and the earthing switch
- 7 Lever hub socket for the switch-disconnector control mechanism in the transformer's outgoing feeder
- 8 Fuse tripping indicator
- 9 Vacuum circuit-breaker position indicator
- 10 Lever hub socket for the vacuum circuit-breaker control mechanism in the transformer's outgoing feeder
- 11 Interlocking of the vacuum circuit-breaker and disconnector
- 12 Protection relay tripping indicator
- 13 Interlocking between the disconnector and earthing switch
- 14 Lever hub socket for the disconnector
- 15 Disconnector position indicator
- 16 Optional: lever hub socket for the manual back-up operation of the switch-disconnector motorised mechanism (in this case, the opening 7 or 4 is blocked off at the factory)
- 17 Pushbutton to close circuit-breaker (CB, CBb)
- 18 Pushbutton to open circuit-breaker (CB, CBb)
- 19 Operations counter
- 20 Lever hub for circuit-breaker spring arming
- 21 Indicator showing the status of the spring (primed or released)

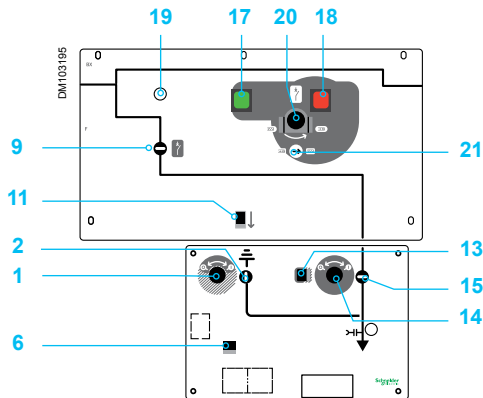

Feeder cable protection with vacuum circuit-breaker (CB)

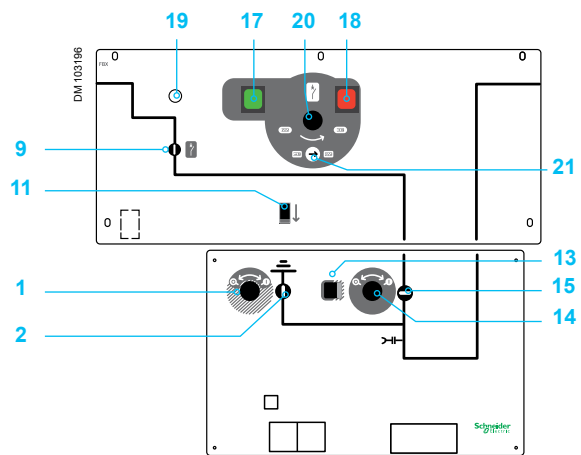

Busbar protection with vacuum circuit-breaker (CBb)

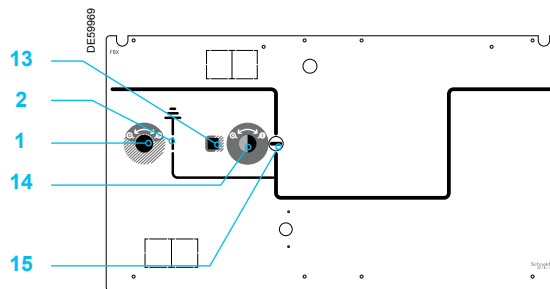

Busbar switch-disconnector (Sb)

## Padlocking

The actuator's operating hub can be controlled by padlock (optional).



Obstruction of the lever hub socket by padlock

### Interlocking of the functional units

During the development of FBX switchboard, the accent was placed on personnel safety and the reliability of the operation.

An interlocking system prevents any incorrect use.

Thus, the operating levers can only be inserted if the service status permits it.

Access to the cables compartment and to the fuses is only possible if the appropriate outgoing feeder is connected to earth.

The switchboards are equipped in production series with the following interlocks:

#### Functional unit with switch-disconnector and earthing switch, switch-disconnector fuse combination (C, T1 and Sb functions)

Interrupting mechanism	Position	Interlock status...		
		Switch-disconnector	Earthing switch	Cables compartment panel or fuses
Switch-disconnector	Closed	–	Locked	Locked
	Open	–	Unlocked	Locked, if earthing switch is open
Earthing switch (ES)	Closed	Locked	–	Unlocked
	Open	Unlocked	–	Locked
Cable or fuses compartment panel (Sb function not concerned)	Removed	Locked	Locked	–
	Fitted	<ul style="list-style-type: none"> <li>■ Unlocked, if earthing switch is open</li> <li>■ Locked, if earthing switch is closed</li> </ul>	Unlocked	–

Option: switch-disconnector – locking of the cables compartment panel, for example, for the cable tests.

#### Functional unit with vacuum circuit-breaker, disconnector and earthing switch (T2, CB and CBb function)

Interrupting mechanism	Position	Interlock status...						
		Disconnector		Earthing switch		Circuit-breaker		Cable compartment panel (not CBb)
		Open	Closed	Open	Closed	Open	Closed	
Disconnector (Disc.)	Open	–	–	Unlocked	Unlocked	Unlocked	Unlocked	–
	Closed	–	–	Locked	–	Unlocked	Unlocked	–
Earthing switch (ES)	Open	Unlocked	Unlocked	–	–	Unlocked	Unlocked	Locked
	Closed	Locked	–	–	–	Unlocked	Unlocked	Unlocked
Circuit-breaker	Open	<ul style="list-style-type: none"> <li>■ Unlocked if ES open</li> <li>■ Locked if ES closed</li> </ul>	Unlocked	<ul style="list-style-type: none"> <li>■ Unlocked if DISC open</li> <li>■ Locked if DISC closed</li> </ul>	Unlocked	–	–	–
	Closed	Locked	Locked	<ul style="list-style-type: none"> <li>■ Unlocked if DISC open</li> <li>■ Locked if DISC closed</li> </ul>	Unlocked	–	–	–

## Extensibility of FBX-E

- FBX-E offers extensible configurations for secondary distribution applications.
- The connection of each functional unit allows for multiple combinations depending on the installation requirements.
- FBX-E permits the connection of additional units on the left or right-hand side, thereby offering greater flexibility in the choice and positioning of the medium voltage switchboard functions.
- The installation and in-line connection of FBX-E does not require any handling of gas.
- Maximum current: 630 A

## Erection and assembly

The extension is a very simple process thanks to:

- The A-link device used to connect the busbars of two cubicles.
- Variations in positioning are compensated by fixed, spherical contacts and mobile couplings that can be adjusted axially and radially.
- Highly secure dielectric seals made with silicone insulating conical connectors adapted to the electrical voltage.

The assembly of the insulating connectors is maintained by a mechanical force generated by:

- Integrated guiding pins for the correct alignment of the cubicles
- An assembly by bolts secured by mechanical stops.

During the assembly of an extension cubicle, an additional space of at least 450 mm is necessary to allow for handling.



*A-Link device for the in-line connection of the FBX-E*

**FBX switchboard is equipped with PF250 or PF630 plug-in bushings:**



**C / T2 / CB / T1 (optional on T1): PF630 plug-in bushing**  
NF EN 50181, with C type connection (I<sub>r</sub>: 630 A; Ø M16 mm)



**T1 (as standard): PF250 plug-in bushing**  
NF EN 50181, with A type connection (I<sub>r</sub>: 250 A; contact finger Ø M7.9 +0.02/-0.05 mm)

## Cable compartment

The cables connection compartment has been designed to accept connection systems that are:

- Completely insulated
- In metallic housing
- Partially insulated.

Cable support mountings are adjustable horizontally and vertically to enable installation of various cable systems. The cable mountings are equipped with either round or long holes for standard cable terminals.

Additional support structures can be supplied (available only in the 1,380 mm height version) for the installation of two cables per phase cable plug-in connections or surge arresters.

**Bushing connector cones in accordance with NF-EN-50181:**

Switchboard function	R / RE	C	T1	T2 / CB
Connector cone Type A (250 A)	—	—	■	—
Connector cone Type C (630 A)	■	■	■ (optional)	■

**Type A (250 A)**

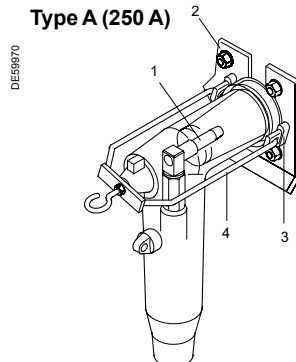

- 1 - Sliding contact pin
- 2 - Support plate
- 3 - Mounting flange
- 4 - Mounting device

**Type C (630 A)**

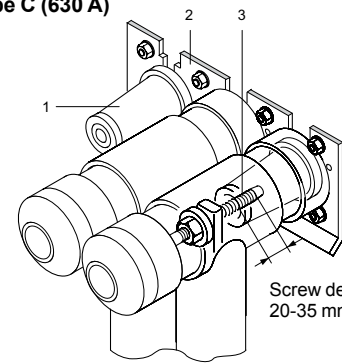

- 1 - Cross member - Male
- 2 - Support plate
- 3 - Screw contact

Screw depth 20-35 mm

## Type of connection

FBX cable compartment is spacious and allows for various connections (cf. § Selection of cables):

- Single cable per phase
- Two cables per phase
- Single cable per phase + surge arresters
- A triple cable per phase connection is also available (please consult us)
- No cable - bushing protected by insulating plug.

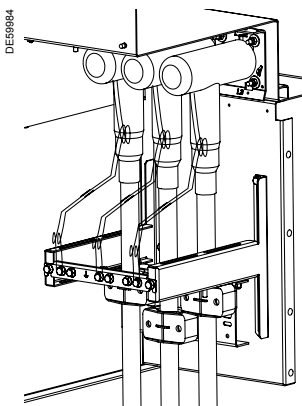

Single cable per phase connection

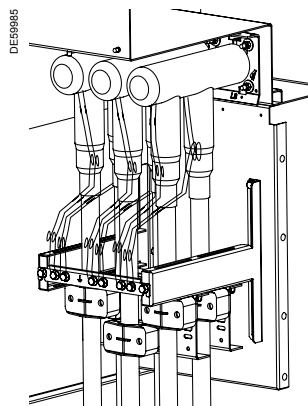

Two cables per phase (only available in the FBX 1,380 mm height version)

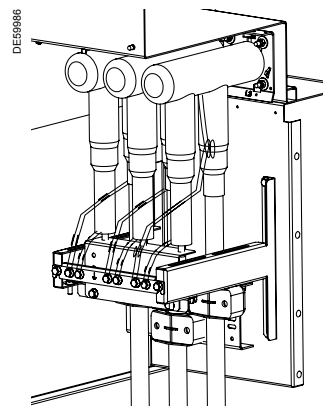

Cables & surge arresters (only available in the FBX 1,380 mm height version)

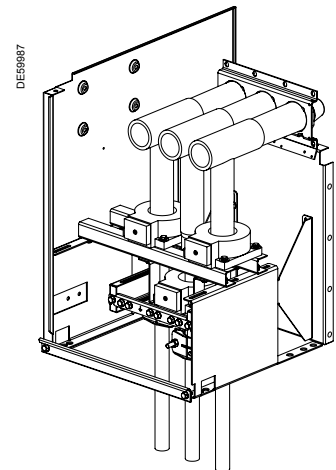

CB cable compartment with metering CT cores



PE68615



FBX with fuse protection

## Fuse compartment

The fuses are located within plugged and insulated fuse-holders. These fuse holders are integrated into the gas tank and offer the following advantages:

- The electrical field is placed in the SF6 gas,
- The fuse-holder plugs are placed outside the electrical field which is contained in the tank filled with SF6 gas,
- The fuse-holder is located in the tank and cannot be affected by outside elements,
- The dielectric strength of the plug is thus not ensured by the compression of a seal but by an insulating distance.

Available option: watertight plugs.

## Fuse tripping

The stored energy mechanism and the tripping striker open all three phases thanks to the switch-disconnector. If the striker on a single HV fuse is actuated, all three phases are disconnected.

## Fuse replacement

The interlocking guarantees maximum safety for the personnel during the replacement of fuses. The fuse compartment panel can only be opened if it has been earthed correctly. Inversely, the earthing can only be removed once the fuse compartment panel is closed and locked.

Two earthing switches with making capacity (both upstream and downstream from the fuses) allow the fuses to be replaced without using auxiliary equipment. The two earthing switches with making capacity are operated by a common spring loaded mechanism.

PE68616



*It is recommended that you replace all three fuses at the same time*

PE68617



*Do not turn the gripping surfaces but use them to pull the fuse out*

PE68618



*Removal of the fuse*



---

<b>C, Sb, R, RE functions</b>	<b>26</b>
<b>T1 function</b>	<b>27</b>
<b>T2 function</b>	<b>28</b>
<b>CB, CBb functions</b>	<b>29</b>
<b>Maximum number of mechanism operations</b>	<b>30</b>
<b>Choice of mechanisms and equipment</b>	<b>31</b>
<b>SFU/SU, SF/SU operating mechanisms</b>	<b>32</b>
<b>C 150 operating mechanisms</b>	<b>33</b>
<b>M function</b>	<b>34</b>

Characteristics of the C, Sb, R, RE functions (switch-disconnector) <sup>(1)</sup>									
<b>Rated voltage</b>		<b>kV</b>	<b>12</b>			<b>17.5</b>		<b>24</b>	
Rated frequency		Hz	50/60			50/60		50/60	
<b>Rated lightning impulse withstand voltage</b>									
Directly earthed		kV	75			95		125	
On the sectionalized distance		kV	85			110		145	
<b>Rated power frequency withstand voltage</b>									
Directly earthed		kV	28			38		50	
On the sectionalized distance		kV	32			45		60	
<b>Level of insulation for the SF6 pressure - Pre = 0.00 MPa</b>									
Rated lightning impulse withstand voltage		kV	75			95		95	
Rated power frequency withstand voltage		kV	28			38		50	
<b>Level of insulation of the sectionalized distance for the cable test</b>									
Energized busbar		Ur kV	12			17.5		24	
Maximum AC feeder test voltage (30 min)		kV 0.1 Hz	18			26		35	
Maximum DC feeder test voltage (15 min)		kV	48			60		96 <sup>(2)</sup>	
<b>Rated current</b>									
Busbar, C, R, RE functions		A	630 / 1250			630 / 1250		630 / 1250	
Busbar, Sb function		A	630			630		630	
Outgoing feeder		A	630			630		630	
Rated peak current		kA	40	52.5	62.5	40	52.5	40	50
Rated short-circuit making capacity		kA	40	52.5	62.5	40	52.5	40	50
Rated short time current, main electrical circuit		1 s kA	16	21	25	16	21	16	20
		3 s kA	16	21	–	16	21	16	20
Rated short-time current of earthing circuit		1 s kA	16	21	25	16	21	16	20
		3 s kA	16	21	–	16	21	16	20
Rated network load and closed-loop breaking current		A	630			630		630	
Rated no-load cable-breaking current		C1 A	160			160		160	
Rated breaking current under earth fault conditions		A	600			600		600	
Rated no-load cable breaking current under earth fault conditions		A	277			277		277	
<b>Number of operating cycles without inspection</b>									
Mechanical: Switch-disconnector/ Earthing switch		M1/M0	1000			1000		1000	
Electrical: Rated current		E3	100			100		100	
Short circuit making		Switch-disconnector	E3			5		5	
		Earthing switch	E2			5		5	

(1) General use switch. The characteristics of the switch-disconnector are not applicable to the R and RE functions.

(2) For the first cable test on a new unit. Later tests can be carried out at 67 kV.

Characteristics of the T1 function (switch-disconnector fuse combination)										
<b>Rated voltage</b>	<b>kV</b>	<b>12</b>				<b>17.5</b>		<b>24</b>		
Rated frequency	Hz	50/60				50/60		50/60		
<b>Rated lightning impulse withstand voltage</b>										
Directly earthed	kV	75				95		125		
On the sectionalized distance	kV	85				110		145		
<b>Rated power frequency withstand voltage</b>										
Directly earthed	kV	28				38		50		
On the sectionalized distance	kV	32				45		60		
<b>Level of insulation for the SF6 pressure - Pre = 0.00 MPa</b>										
Rated lightning impulse withstand voltage	kV	75				95		95		
Rated power frequency withstand voltage	kV	28				38		50		
<b>Rated current for continual service</b>										
Busbar	A	630 / 1250				630 / 1250		630 / 1250		
Outgoing feeder	A	Refer to the fuses selection table								
Rated peak current, main circuit (prospective current, limited by fuses)	A	40	52.5	52.5	62.5	40	52.5	40	50	
Rated short-time current, downstream of fuse protection circuit	1 s kA	1	1	5	5	1	5	1	5	
	3 s kA	–	–	3	3	–	3	–	3	
Rated peak current, downstream of fuse protection circuit	kA	2.5	2.5	13	13	2.5	13	2.5	13	
Rated short circuit making current, downstream of fuse protection circuit	kA	2.5	2.5	13	13	2.5	13	2.5	13	
Rated short-time current of earthing circuit	1 s kA	16	21	21	25	16	21	16	20	
	3 s kA	16	21	21	–	16	21	16	20	
Rated no-load cable-breaking current	A	60				60		60		
Rated breaking current under earth fault conditions	A	200				200		200		
Rated no-load cable breaking current under earth fault conditions	A	87				87		87		
Rated transfer current in accordance with IEC 62271-105	A	2000				1100		1100		
Opening time in the case of fuse striker tripping T <sub>0</sub>	ms	34				34		34		
<b>Number of operating cycles without inspection</b>										
Mechanical: Switch-disconnector/ Earthing switch	M1/M0	1000				1000		1000		
Electrical:	Rated current	E1 <sup>(1)</sup>				10		10		
	Short circuit making	Switch-disconnector	E3				5		5	
		Earthing switch	E2				5		5	

(1) E3 (100 x rated current) on request.

Characteristics of the T2 function (vacuum circuit-breaker)										
<b>Rated voltage</b>	<b>kV</b>	<b>12</b>			<b>17.5</b>		<b>24</b>			
Rated frequency	Hz	50/60			50/60		50/60			
<b>Rated lightning impulse withstand voltage</b>										
Directly earthed	kV	75			95		125			
On the sectionalized distance	kV	85			110		145			
<b>Rated power frequency withstand voltage</b>										
Directly earthed	kV	28			38		50			
On the sectionalized distance	kV	32			45		60			
<b>Level of insulation for the SF6 pressure - Pre = 0.00 MPa</b>										
Rated lightning impulse withstand voltage	kV	75			95		95			
Rated power frequency withstand voltage	kV	28			38		50			
<b>Level of insulation of the sectionalized distance for the cable test</b>										
Energized busbar	Ur	kV	12			17.5		24		
Maximum AC feeder test voltage (30 min)	kV	0.1 Hz	18			26		35		
Maximum DC feeder test voltage (15 min)	kV	48			60		96 <sup>(2)</sup>			
<b>Rated current</b>										
Busbar	A	630 / 1250			630 / 1250		630 / 1250			
Outgoing feeder	A	400 / 630			400 / 630		400 / 630			
Rated peak current	kA	40	52.5	62.5	40	52.5	40	50		
Rated short-circuit making capacity	kA	40	52.5	62.5	40	52.5	40	50		
Rated short time current, main electrical circuit	1 s	kA	16	21	25	16	21	16	20	
	3 s	kA	16	21	–	16	21	16	20	
Rated short-time current of earthing circuit	1 s	kA	16	21	25	16	21	16	20	
	3 s	kA	16	21	–	16	21	16	20	
Rated short circuit breaking current	kA	16	21	25	16	21	16	20		
Percentage of the direct current component	%	28			28		28			
Rated operating sequence <sup>(1)</sup>	O - 3 min CO									
Rated no-load cable-breaking current	A	25			31.5		31.5			
<b>Rated operating time</b>										
Opening with tripping release	ms	25 to 60			25 to 60		25 to 60			
Breaking with tripping release	ms	55 to 65			55 to 65		55 to 65			
Arcing	ms	< 15			< 15		< 15			
Closing	ms	30			30		30			
<b>Number of operating cycles without inspection</b>										
Mechanical:	Vacuum circuit-breaker	M1	2000			2000		2000		
	Disconnecter/ Earthing switch	M0	1000			1000		1000		
Electrical:	Short circuit making	Disconnecter	E2	5			5		5	
		Earthing switch	E2	5			5		5	
	Vacuum circuit-breaker	At E2 rated current		2000			2000		2000	
		At rated short circuit breaking current		50			50		50	

(1) Spring-loaded current making and breaking mechanism with stored energy and motor.

(2) For the first cable test on a new unit. Later tests can be carried out at 67 kV.

Characteristics of the CB, CBb functions (vacuum circuit-breaker)									
<b>Rated voltage</b>	kV		<b>12</b>			<b>17.5</b>		<b>24</b>	
Rated frequency	Hz		50/60			50/60		50/60	
<b>Rated lightning impulse withstand voltage</b>									
Directly earthed	kV		75			95		125	
On the sectionalized distance	kV		85			110		145	
<b>Rated power frequency withstand voltage</b>									
Directly earthed	kV		28			38		50	
On the sectionalized distance	kV		32			45		60	
<b>Level of insulation for the SF6 pressure - Pre = 0.00 MPa</b>									
Rated lightning impulse withstand voltage	kV		75			95		95	
Rated power frequency withstand voltage	kV		28			38		50	
<b>Level of insulation of the sectionalized distance for the cable test</b>									
Energized busbar	Ur	kV	12			17.5		24	
Maximum AC feeder test voltage (30 min)	kV 0.1 Hz		18			26		35	
Maximum DC feeder test voltage (15 min)	kV		48			60		96 <sup>(2)</sup>	
<b>Rated current for continual service</b>									
Busbar, CB function	A		630 / 1250			630 / 1250		630 / 1250	
Busbar, CBb function	A		630			630		630	
Circuit-breaker	A		630			630		630	
Rated peak current	kA		40	52.5	62.5	40	52.5	40	52.5
Rated short-circuit making capacity	kA		40	52.5	62.5	40	52.5	40	52.5
Rated short time current, main electrical circuit	1 s	kA	16	21	25	16	21	16	21
	3 s	kA	16	21	–	16	21	16	21
Rated short-time current of earthing circuit	1 s	kA	16	21	25	16	21	16	21
	3 s	kA	16	21	–	16	21	16	21
Rated short circuit breaking current	kA		16	21	25	16	21	16	21
Percentage of the direct current component	%		40			40		40	
Rated operating sequence <sup>(1)</sup>	O - 0.3 s - CO - 15 s - CO								
Rated no-load cable-breaking current	A		25			31.5		31.5	
<b>Rated operating time</b>									
Opening with tripping release	ms		25 to 60			25 to 60		25 to 60	
Breaking with tripping release	ms		55 to 65			55 to 65		55 to 65	
Arcing	ms		< 15			< 15		< 15	
Closing	ms		30			30		30	
<b>Number of operating cycles without inspection</b>									
Mechanical: Vacuum circuit-breaker	M1 / M2		2000 / 10000			2000 / 10000		2000 / 10000	
	Disconnecter/ Earthing switch		M0			1000		1000	
Electrical: Short circuit making	Disconnecter	E2	5			5		5	
		Earthing switch	E2			5		5	
	Vacuum circuit-breaker	At rated current		2000			2000		2000
	At rated short circuit breaking current		50			50		50	

(1) Spring-loaded current making and breaking mechanism with stored energy and motor.

(2) For the first cable test on a new unit. Later tests can be carried out at 67 kV.

## C function

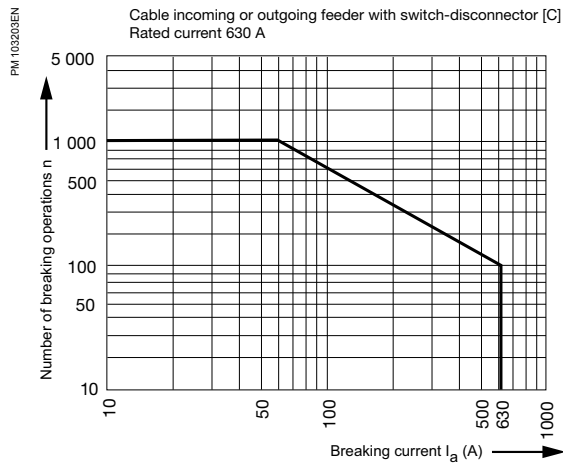

## T1 function

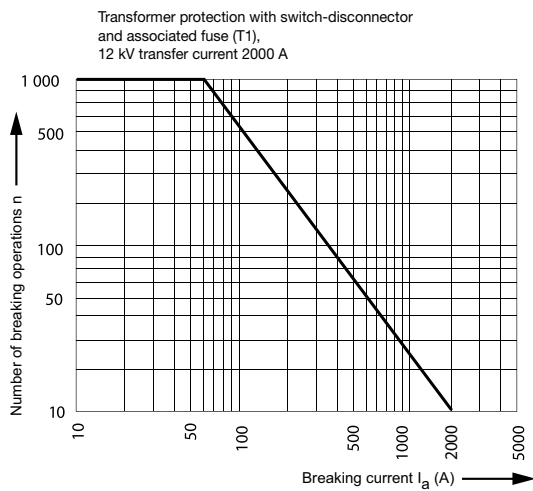

## T1 function

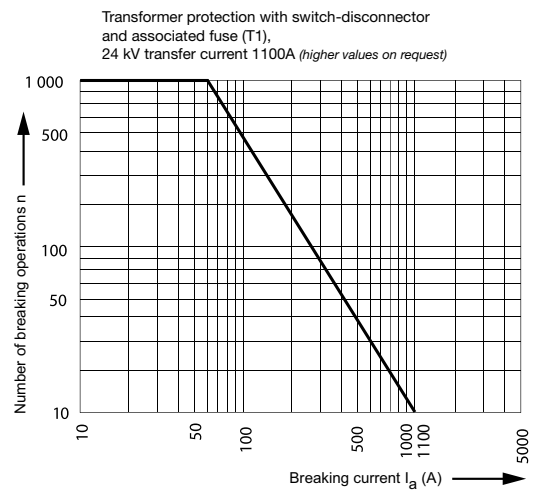

## CB630A function (M2)

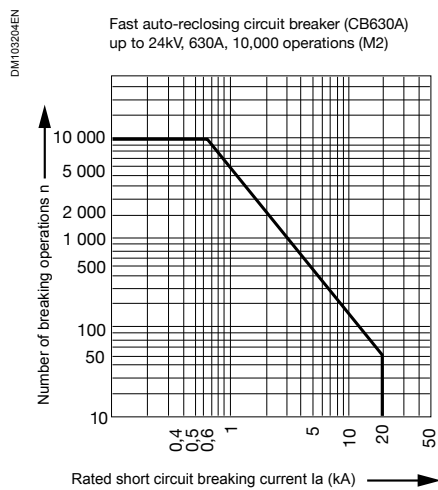

## T2 / CB630A (M1) / CBb functions

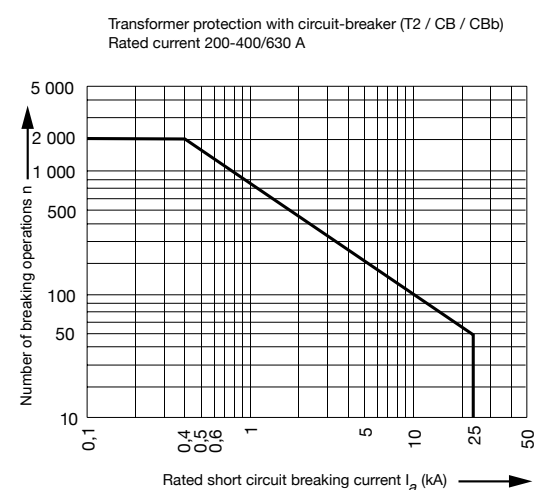



# Choice of mechanisms and equipment

## Mechanism operating principles

<b>SFU (tumbler)</b>	<p><b>It is a tumbler mechanism with a dead point passage. The energy is stored by tumbler mechanism.</b></p> <ul style="list-style-type: none"> <li>■ <b>Manual:</b> the opening or closing operation is manual and independent of the operator. The operation is performed without any duration or time constraint</li> <li>■ <b>Motorized:</b> the opening or closing operations are performed by a motor without duration or time constraint.</li> </ul>
<b>SF (tumbler with 1 latch for opening)</b>	<p><b>It is a tumbler mechanism for closing, with a latch-in feature for opening. The energy needed for opening is stored while closing.</b></p> <ul style="list-style-type: none"> <li>■ <b>Manual:</b> the operator manually closes the switch-disconnector in one single operation, and in the same time loads a spring for next opening. The mechanism is thus ready for a snap opening operation. Tripping can be performed with a coil, a fuse striker or a push-button.</li> <li>■ <b>Motorized:</b> the closing operation is performed by a motor. The opening operation can be done with the motor or with a shutter release.</li> </ul>
<b>SU (tumbler)</b>	<p><b>It is a tumbler mechanism for closing operation.</b></p> <p>The opening is manual and dependent of the operator, a spring is loaded and stores energy for next closing. The closing is independent of the operator, the energy is released from the spring and closes the earthing switch in a snap operation.</p>
<b>C 150 mechanism</b>	<p><b>These operating mechanisms use the energy stored by springs to close and open the circuit-breaker on the CB and CBb functions. There are two types:</b></p> <ul style="list-style-type: none"> <li>■ <b>Manual:</b> the operator manually operates to load the control mechanism's spring. The spring is held in place by a latch, freed manually by a mechanical button, causing: <ul style="list-style-type: none"> <li>□ the release of the spring</li> <li>□ the closing of the CB</li> <li>□ the arming of the trip spring, now held in place by a latch.</li> </ul>                     It is thus possible to open the circuit-breaker by freeing the trip spring latch manually (mechanical button) or electrically (electro-magnet).                     <p><u>Note:</u> with the circuit-breaker closed, it is possible to rearm the closing spring, which authorises a rapid re-closure cycle.</p> </li> <li>■ <b>Motorized:</b> the closing spring is armed by a motor (arming time &lt; 7 s). Opening and closure operations are carried out electrically (magnets).                     <p><u>Note:</u> It is possible to manually arm, close and trip the circuit-breakers.</p> </li> </ul>

Type of operating mechanism		Functions							
		C	T1	T2	R	Re	CB	CBb	Sb
Switch-disconnector	SFU	■ SFU	–	■ SFU	–	–	■ SFU	■ SFU	■ SFU
	SF	□	■	–	–	–	–	–	□
Earthing switch	SU	■ SU	■ SU	■ SU	–	■ SU	■ SU	■ SU	■ SU
Circuit-breaker	SF	–	–	■	–	–	–	–	–
	C150	–	–	–	–	–	■	■	–
Equipment		C	T1	T2	R	Re	CB	CBb	Sb
Manual opening and closing		■	■	■	–	■	■	■	■
Mechanical position indicator		■	■	■	–	■	■	■	■
Motorization		□	□	□	–	–	■	□	□
Trip coil		□ if SF drive	□	□	–	–	■	■	–
2nd trip coil		–	–	□	–	–	□	□	–
Autonomous tripping device without any auxiliary source (striker)		–	–	–	–	–	□	□	–
Undervoltage tripping coil		–	–	□ <sup>(1)</sup>	–	–	□	□	–
Closing coil		–	–	–	–	–	□	□	–
Operating counter		–	–	□	–	–	■	■	–
Auxiliary contacts		C	T1	T2	R	Re	CB	CBb	Sb
Switch-disconnector position	Manual: 2 NO + 2 NC	□	□	□	–	–	□	□	□
	Motorized: 2 NO + 2 NC	–	–	–	–	–	–	–	–
Earthing switch position	1 NO and 1 NF	□	□	□	–	□	□	□	□
Vacuum circuit-breaker position	Manual: 2 NO + 2 NC	–	–	□	–	–	□	□	–
	Motorized: 2 NO + 2 NC	–	–	–	–	–	–	–	–
Fuse blown indicators	2 O/C inverters	–	□	–	–	–	–	–	–

Legend: ■ Standard  
 □ Option  
 (1) Consult us for availability

The connection and wiring diagrams for the motorized mechanism, the magnetic tripping devices and auxiliary contacts are supplied in the event of an order.

# SFU/SU, SF/SU operating mechanisms

## Electrical characteristics of the SFU/SU, SF/SU operating mechanisms

Reference standards			IEC								
Type of current			DC						AC		
Rated supply voltage	V		24	48	60	110	125	220	100/110	120/125	230
Frequency	Hz		-						50/60		
<b>Rearming motor</b>											
Voltage range	% of Un		85 to 110						85 to 110		
Max. absorbed power			150 W						150 VA		
Starting current	SFU/SU or SF/SU drive	A	13.3	12.1	8.4	4.7	4.1	2.5	6.9	6.8	3.7
Absorbed current	SFU/SU or SF/SU drive	A	5.5	2.8	2.2	1.2	1.1	0.6	2.3	2.2	1.2
Rearm time	SFU/SU or SF/SU drive	s	< 6						< 6		
<b>Trip coil</b>											
Coil current	A		6	3	2.5	1	1	0.5	1	0.9	0.5
Undervoltage trip coil	V		24/60						230		
<b>Auxiliary contacts</b>											
Rated voltage	V		24	48	60	110	125	220	100/110	120/125	230
Rated current	A		10						10		
Short circuit current, 30 ms	A		100						100		
Breaking capacity (L/R ≤ 20 ms)	SFU/SU or SF/SU drive	A	8	4	3	2	1	0.5	-		
Breaking capacity U ≤ 230 Vac (resistive)	SFU/SU or SF/SU drive	A	-						10		

Electrical characteristics of the C 150 operating mechanisms			
Reference standards		IEC	
Type of current		DC	AC
Rated supply voltage	V	24 - 48 - 60 - 110 - 125 - 220	120 - 230
Frequency	Hz	–	50/60
<b>Rearming motor</b>			
Voltage range	% of Un	85 to 110	85 to 110
Max. absorbed power		100 W	150 VA
Starting current	A	(*) / 24 Vdc 14.7 A / 48 Vdc 10.9 A / 60 Vdc 6.6 A / 110 Vdc 5.1 A / 125 Vdc 3.3 A / 220 Vdc	8.5 A / 110 Vac 4.7 A / 230 Vac 5.6 A / 125 Vac
Absorbed current	A	(*) / 24 Vdc 5.1 A / 48 Vdc 3.4 A / 60 Vdc 1.7 A / 110 Vdc 2.0 A / 125 Vdc 1.0 A / 220 Vdc	3.5 A / 110 Vac 1.8 A / 230 Vac 2.1 A / 125 Vac
Rearm time	s	< 6.5	< 6.5
<b>Tripping device</b>			
<b>Tripping coil</b>			
Voltage range	% of Un	70 to 110	85 to 110
Absorbed power	W/VA	960 W / 24 Vdc 480 W / 48 Vdc 450 W / 60 Vdc 620 W / 110 Vdc 521 W / 125 Vdc 373 W / 220 Vdc	620 VA / 110 Vac 521 VA / 125 Vac 407 VA / 230 Vac
<b>Undervoltage coil</b>			
Closing voltage range	% of Un	> 35	> 35
Tripping voltage	% of Un	70 to 35	70 to 35
Absorbed power	W/VA	240 W - 4.7 W / 24 Vdc 256 W - 4.7 W / 48 Vdc 248 W - 7.0 W / 60 Vdc 173 W - 4.4 W / 110 Vdc 166 W - 4.3 W / 125 Vdc 194 W - 3.5 W / 220 Vdc	173 VA - 4.4 VA / 110 Vac 166 VA - 4.3 VA / 125 Vac 194 VA - 3.5 VA / 220 Vac
<b>Autonomous tripping device without any auxiliary source (striker)</b>			
		The low energy release type MITOP, trips at 200 µF / 12 V Trip energy ≤18 mJ	
<b>Closing device</b>			
Voltage range	% of Un	85 to 110	85 to 110
Absorbed power	W/VA	960 W / 24 Vdc 480 W / 48 Vdc 450 W / 60 Vdc 620 W / 110 Vdc 521 W / 125 Vdc 373 W / 220 Vdc	620 VA / 110 Vac 521 VA / 125 Vac 407 VA / 230 Vac
<b>Auxiliary contacts</b>			
Rated current	A	10	10
Breaking capacity 110 Vdc (L/R = 10 ms)	A	1	–
Breaking capacity 230 Vac Cos φ = 0.4	A	–	10

(\*) Please consult us for current value

### Characteristics of the M1, M2, M3, M4 functions

<b>Rated voltage</b>	<b>kV</b>	<b>12</b>	<b>17.5</b>	<b>24</b>				
Rated frequency	Hz	50/60	50/60	50/60				
<b>Rated lightning impulse withstand voltage</b>								
Directly earthed	kV	75	95	125				
On the sectionalized distance	kV	85	110	145				
<b>Rated power frequency withstand voltage</b>								
Directly earthed	kV	28	38	50				
On the sectionalized distance	kV	32	45	60				
<b>Rated current</b>								
Outgoing feeder	A	630	630	630				
Rated peak current	kA	40	52.5	62.5	40	52.5	40	50
Rated short time current, main electrical circuit	1 s kA	16	21	25	16	21	16	20
	3 s kA	16	21	–	16	21	16	20
Rated short-time current of earthing circuit	1 s kA	16	21	25	16	21	16	20
	3 s kA	16	21	–	16	21	16	20

### Characteristics of the current and voltage transformers

Current and voltage transformers in compliance with the DIN 42600 standard (narrow version) must be used in metering cubicles.

**Remarks:**

- Installation of current and voltage metering devices is possible with or without a selector switch,
- Option: a voltage indicator can be added
- Pre-assembled cable connections can be purchased as an option.

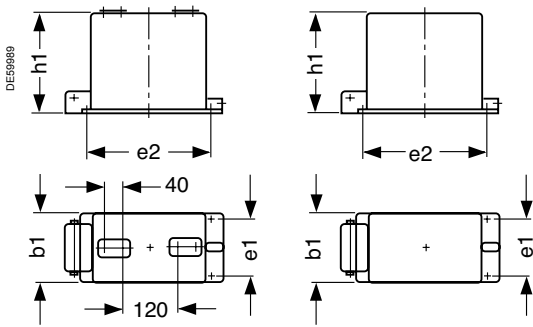

Current transformer (C)  
(DIN 42600, Section 8)

Single phase voltage transformer (W)  
(DIN 42600, Section 9)

Dimensions	Um (kV)	
	12 kV version	24 kV version
b1	148	178
e1	125	150
e2	270	280
h1	220	280





---

<b>Protection relays</b>	<b>38</b>
Sepam & MiCOM	
MiCOM P114S	
DPX-1	
<b>Fault passage indicators</b>	<b>42</b>
<b>Voltage indicator and relay</b>	<b>43</b>
<b>Control</b>	<b>44</b>



PE60300



### Protection relays

#### Sepam: protection digital relays

Sepam is a range of digital monitoring protection and control units. Sepam is at the centre of the protection, monitoring and control system for the FBX functional units: all of the necessary protection, metering, control, monitoring and signalling functions are performed by Sepam. The Sepam range consists of the Sepam series 10, series 20, series 40, series 60 and series 80, a range of modular protection relays to adapt precisely to your needs.

#### MiCOM protection relays

MiCOM protection provides the user with a choice of cost-optimised solutions for specific protection requirements within the distribution network. The MiCOM relay series offers comprehensive protective function solutions for all power supply systems, as well as for the various functional and hardware project stages.

With their modular design, the MiCOM device platforms provide the user with multifunctional equipment that can act as :

- Grid protection equipment, and
- Combined protection and control systems
- MiCOM devices integrate most standard communication protocols used in station control systems and SCADA systems
- Due to the continuous further development of these products, compatibility with technical progress in the field of switchgear and controlgear communication is ensured.

PM1102906



MiCOM offers varying levels of functionality and hardware:

- **Series 10** is designed for universal overcurrent protection for the primary or back-up protection on LV or MV systems
- **Series 20** fulfills the basic requirements of industrial, utility and building applications, providing simplicity and ease of use in a wide range of installations
- **Series 30** is designed to meet the rigorous requirements of MV & HV applications with particular focus on feeder and transformer protection and control
- **Series 40** fulfills the protection requirements for a wide market of utility and industrial systems and offers a complete range of protection functions

#### Autonomous Protection Relay

The following relays can be directly integrated behind FBX front face to have space saving.

- MiCOM P114S
- DPX-1
- Woodward WIC





MiCOM P114S

### Customer Benefits

- No need of auxiliary supply
- Small dimensions of protection system (CTs and relay)
- Optimized cost of secondary equipment
- Fast setting via DIP switches
- Easy testing of protection system (CT test winding)

### Functions overview

<b>50/51</b>	Three-phase overcurrent $tI >>$ (DT)
<b>50/51</b>	Three-phase overcurrent $tI >$ (DT or IDMT: SI, VI, EI, LTI, RI, HV-Fuse, FR-Fuse)
<b>50N/51N</b>	Earth fault overcurrent $tI_o >$ (DT)
	External Voltage Trip Input (P114S is supplied from this voltage input)
	Output for low energy CB coil (24VDC, 0.1J)
	Output for Flag Indicator (24V, 0.01J)
	Fault record for the 5 most recent trips
	USB port for local downloading of settings and/or fault records (the relay can be supplied via USB port)
	Setting software MiCOM S1 (USB port)

### MiCOM P114S protection relay

MiCOM P114S are numerical relays designed to offer overcurrent and earth fault protection without requiring any external auxiliary supply. They can be fully integrated at the front of the FBX without installing it in the low voltage compartment. They can be applied to medium-voltage electrical systems. They are particularly suitable for all applications where small dimensions and/or optimised costs of whole protective systems (CTs and secondary equipment) are required. MiCOM P114S are connected to specific ring CTs (ordered with relay) to integrate protective system in the optimum way. A capacitance discharge output capable of putting out sufficient power to a low energy trip coil of circuit breaker. An external flag indicator is used to indicate remotely or locally that a trip has occurred. All settings are made by using DIP switches.

### Application

MiCOM P114S numerical overcurrent protection relays provide a simple and cost-efficient solution where no external auxiliary power supply is available or guaranteed.

Typical applications are:

- A cost-optimized MV switchboard with small dimensions (for example: a gas-isolated ring, main unit type FBX)
  - Industrial plants
  - Low-end MV utilities substation
- P114S is connected to specific ring phase current transformers to optimize protective system (doesn't work with traditional 1A/5A CTs).

### Global functions

The following functions are generally available in P114S:

- CT-powered
- Specific ring phase CTs ordered with relay
- Earth fault current internally derived from phase CTs
- Compact case with small dimensions (HxWxD): 175x106x46
- DIP switches for setting
- Sockets on the front panel of the relay for direct connection of test equipment
- 5 version of CTs cover a wide range of primary nominal current: 16A to 896A only
- Adjusting of nominal current in P114S
- Settings referred to primary nominal current.

### Main functions

The hardware architecture and software algorithms have been studied to operate on very short failure detection times. P114S relay is equipped with circuit breaker trip output (24VDC, 0.1J). A capacitance discharge output is capable of putting out sufficient power to a low energy trip CB coil. An external Flag Indicator can be connected to an independent energy output (24VDC, 0.01J).

The available functions, including protection, inputs and outputs are easily programmable by means of user friendly front panel interface and the S1 software interface. The 4 digit LED display provides the user with key information (faults, measurements, settings etc.).

### MiCOM P114S functions

- Three-phase overcurrent protection (50/51). MiCOM P114S relays provide three phase current inputs. Two independent stages are available. For the first stage ( $tI >$ ) the user may independently select definite time delay or inverse time delay with different type of curves (SI, VI, EI, LTI, RI, HV-Fuse). The second stage can be configured with definite time only.
- Earth fault overcurrent protection (50N/51N). MiCOM P114S relays provide earth fault protection. The earth fault current is derived from the three-phase current. One stage is available ( $tI_o >$ ) with DT characteristic.
- Remote trip input. Remote trip input allows to open circuit breaker if the next outgoing line (line application) or LV side of MV/LV transformer (transformer application) has had trip signal. The AC auxiliary voltage on the terminals supplies P114S and gives trip signal which opens CB, even if there is no current on the terminals of P114S. This input is electrically isolated and can be loaded continuously. Tripping time delay is less than 1s.
- Fault recording. The last 5 faults are stored in FRAM memory of P114S relay.
- MiCOM S1 support software. Support Software MiCOM S1 is available for the entire MiCOM family, including P114S relays. MiCOM S1 is fully Windows TM compatible. This Support Software allows to readout of setting and download fault records. PC connection with P114S is available via USB port on the front panel of relay.

PE59827



DPX-1 autonomous protection relay

### DPX-1 autonomous protection relay

The DPX-1 system, consisting of a compact protection relay and a toroidal type current transformer, has been specially developed for compact medium voltage switchboards with circuit-breakers.

The following protection functions have been integrated into the DPX-1:

- Constant three phase over-current protection with variable tripping times (ANSI 50/51).
- Three phase over-current protection with selection capability characteristics of inverse time and constant time short circuit current element (ANSI 50/51).
- Protection of inverse and constant time earthing over-current by internal calculation (ANSI 50N/51N).

In the DPX-1, the phase current and earth current are calculated using an arithmetic mean value.

### Protection characteristics

- Protection independent from the line current at two levels (UMZ).
- Inverse time delay characteristics with an independent time short circuit current element:
  - Normal Inverse (NINV)
  - Very Inverse (VINV)
  - Extremely Inverse (EINV)
  - Long Inverse (LINV)
  - RI-Inverse (RIINV).
- The system of protection enables a tripping time of 40 ms.
- The tripping time in the event of a fault varies, depending on the fault current level.
- The parameters are adjusted with the rotary switches.
- Any current interruption following tripping of the protection relay is signalled by a warning light on the front panel of the rotary switch.

### Presentation of the adjustment ranges and functions

	Adjustment range	Function
I>	0.5 x - 2.5 x Is	
tI>	0.04 - 300 s	UMZ / DEFT
	Factor (a): 0.05 to 10	NINV, VINV, EINV, RIINV, LINV
I>>	1 x - 20 x Is	UMZ / DEFT
tI>>	0.04 - 3 s	
IE>	0.1 - 2.5 x Is	
tIE>	0.06 - 300 s	UMZ / DEFT

DPX-1 is activated by standard and toroidal type current transformers and is described in the table on the left.

### Standard current transformer

Description	Conversion	Rated power	Degree of precision
CT1	30/1A	1 VA	10P5
CT2	50/1A		5P10
CT3	100/1A		
CT4	200/1A		
CT5	400/1A		
CT6	800/1A		

These standard current transformers are available in these versions.

PE59828



Bottom view of toroidal type current transformers on external-cone cable plug-in terminals (T2 function)

## DPX-1 characteristics curves

Pre-defined time

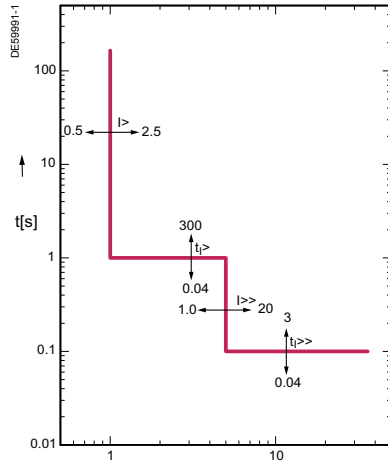

Normal inverse

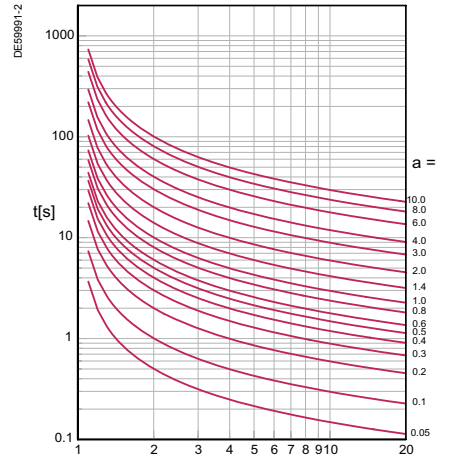

Extremely Inverse

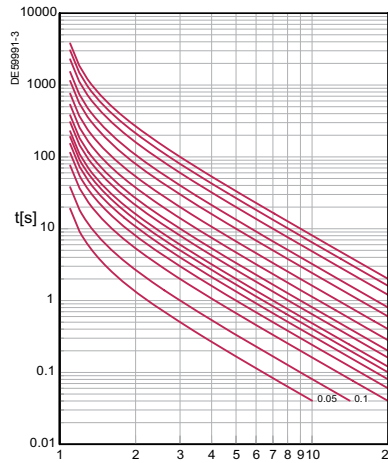

Very Inverse

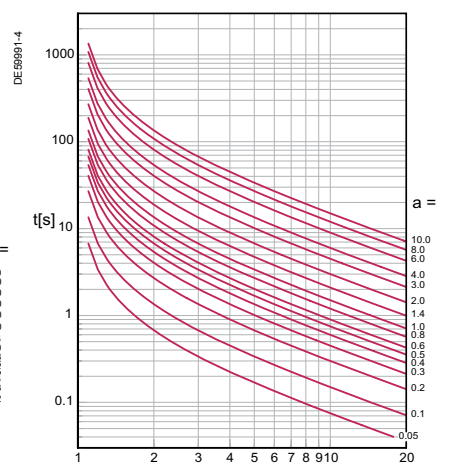

Long Inverse

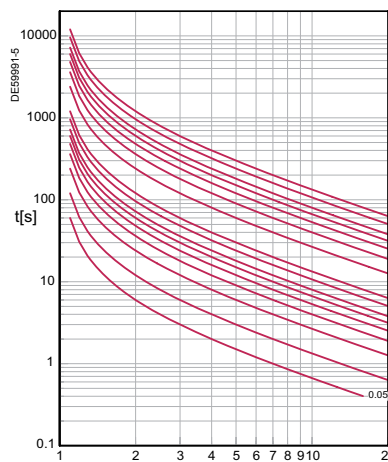

RI Inverse

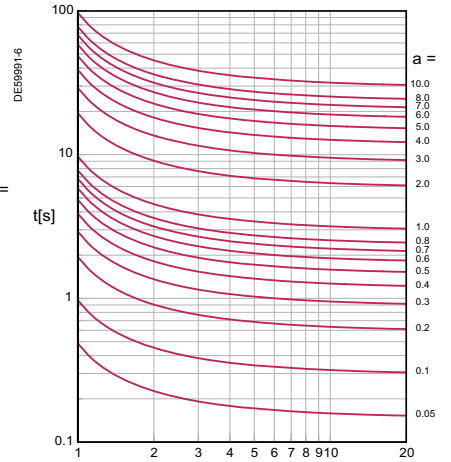



Flair 21D



Flair 22D



Flair 23D



Flair 23DM



Compass B directional fault passage indicator

### Fault passage indicators

To improve your power availability and manage your network load, FBX can be fitted with a variety of fault passage indicators integrated in FBX Low Voltage front panel (non-exhaustive list):

- Easergy Flair 21D, 22D, 23D & 23DM (Schneider Electric)
- Alpha, Sigma or Opto (Horstmann make)
- IKI20 (Kries make).

#### Main characteristics of Easergy Flair 21D and Flair 22D fault passage indicators:

The new version of Easergy **Flair 21D** and **Flair 22D** provides a high visibility flashing led and gives detailed information via the digital display. An outdoor lamp on option can give the fault passage indication without entering the substation.

#### Overcurrent detection

- Automatic mode for automatic adjustment-free calibration of detection thresholds
- Manual mode possible to perform special override settings:
  - Flair 21D: 4 detection thresholds from 200 A to 800 A, in 200 A increments, selectable via microswitch.
  - Flair 22D, Flair 23D and Flair 23DM: 15 detection thresholds from 100 A to 800 A, in 50 A increments (configurable via the front panel keypad).
- Fault acknowledged time:
  - Flair 21D: 60 ms
  - Flair 22D, Flair 23D and Flair 23DM (configurable via the front panel keypad):
    - from 40 to 100 ms in 20 ms increments
    - from 100 to 300 ms in 50 ms increments.

Note: On Flair 23DM, the parameter settings can also be modified remotely via the Modbus link.

#### Earth fault detection

Principle: the detector checks on the 3 phases the current variations (di/dt). A time delay of 70 s is applied for fault confirmation by the upstream protective device.

- Automatic mode for automatic, adjustment-free calibration of detection thresholds
- Manual mode possible to perform special override settings:
  - Flair 21D: 6 detection thresholds from 40 to 160 A, selectable via microswitch
  - Flair 22D, Flair 23D and Flair 23DM (configurable via the front panel keypad):
    - Type A setup:
      - from 20 to 200 A, in 10 A increments (in resistive neutral system), and from 5 to 30A in 5 A increments and from 30 to 200 A, in 10 A (in an isolated and compensated neutral earthing system)
    - Type B setup:
      - from 5 to 30 A in 5 A increments, and from 30 to 200 A in 10 A increments

■ Inrush function: to prevent unwanted detection in the event of load switch-on. Incorporates a 3 s time delay for fault filtering at network power up.

Configurable at 70 s or disabled on Flair 22D, 23D and 23DM.

#### Fault indication

- Signalling
  - As soon as a fault is confirmed, the indication device is activated.
  - Fault indication via a red LED on the front panel
  - Indication of the faulty phase (earth fault) on LCD display
  - Optional remoting of indication to external flashing lamp
  - Activation of a contact for retransmission to the SCADA system.
- Indication reset
  - Automatic reset upon load current recovery (configurable time delay on Flair 22D)
  - Manual reset via front panel button
  - Reset via external Reset input
  - Reset by time delay: fixed (4 hr) for Flair 21D and adjustable using front panel keypad (2 hr to 16 hr) for Flair 22D.

#### Communication

- F23DM provides Modbus communication whilst also acting as a Voltage Detector

To accompany the rise of distributed power generation on distribution networks, FBX can be equipped with directional fault indicators such as:

- Compass B (Horstmann make)
- IKI20a (Kries make).

PE68622



VDS HR and its removable luminous indicator

PE68177



VPIS v2, Voltage Presence Indicator System

PE68144



VPIS-VO

PE68621



IVIS, Voltage presence detection system (IVIS, Intelligent Voltage Information System)

PE67757



VD23 Voltage Detector relay

### Voltage detection systems

The absence, or presence, of voltage at outgoing feeders level can be checked using 3 types of device:

- VDS-HR
- VDS-LR
- VPIS

Voltage indicators and any connectors for warning lights can be found to the top of the FBX front panel.

### VPIS v2: voltage presence indicating system

Description:

- The VPIS V2 is a self-powered voltage presence indicating system, in compliance with the IEC 62271-206 standard
- Connectors on the front panel allow the use of a phase comparator
- Extended lifetime of LEDs on the front panel
- Compatibility with existing MV network devices for replacement.

VPIS-VO:

- VPIS v2 can be fitted with a voltage output cable to interface with the Flair fault passage indicator range or VD23 voltage detection relay, and in particular for power source changeover.

### IVIS : voltage detection system

FBX can be fitted with the VDS-LR IVIS device:

- The integrated IVIS system (Integrated Voltage Detection System) checks for the absence of a voltage.
- Flashing arrow symbols light up on the indicators in case of the presence of a voltage within defined threshold response limits.

The IVIS is equipped with a self-test in order to avoid any electrical tests.

The IVIS system also provides a phase comparison function.

It is equipped with integrated electronics, protected against bad weather conditions and requires no maintenance. It is auto-supplied. An auxiliary contact is available for remote monitoring (optional).

### VD23: Voltage detection relay

VD23 provides information of presence or absence of voltage.

Associated with VPIS-Voltage Output, VD23 is typically used in critical power and safety applications.

Various combinations of voltage detection are possible:

- 3 Ph-N and residual voltage:  $V1 + V2 + V3 + V0$
- 3 Ph-N or Ph-Ph voltage:  $V1 + V2 + V3$  or  $U12 + U13 + U23$
- 1 Ph-N or Ph-Ph or residual voltage:  $V1, V2, V3, U12, U13, U23, V0$ .

VD23 can display the MV network voltage (in % of service voltage), active the relay output R1 to monitor a loss of voltage on 1 phase at least and active the relay output R2 to monitor a presence of voltage on 1 phase at least.

- Auxiliary power supply: from 24 to 48 Vdc
- Assembly: compact DIN format, mounted in the same place as fault passage indicator (format DIN, integrated in switchgear), terminal connexion fitted with VPIS-Voltage Output

□ Compatible with all neutral earthing systems.

### New LPVT options

FBX can now be specified with compact high accuracy Low Power Voltage Transformers (LPVT). These innovative sensors are ideal for the new generation of electronic protection devices and are the only way to measure energy in secondary MV loops.

- Up to Class 0.5 accuracy levels for metering
- Linear wide spectrum voltage range with no ferro resonance characteristics.
- Low power consumption and reduced size - ideal for new or retrofit solutions
- Excellent harmonic performance for Power Quality monitoring
- Increased quality and safety under over-voltage, open circuit, or short circuit conditions
- Easy to install, operate and test - no need to disconnect for cable testing 42kV / 15min
- Comply to international standard : IEC 60044-7

PE58610



Automated substation

### Remote control & monitoring

FBX can be motorized by functional units allowing for the remote control and monitoring of the components of FBX.

Complete automation of the network is therefore possible and avoids costly human interventions on the site.

To enable communication with the network control centres, FBX integrates communication systems such as:

- Modem solutions for telephone lines
- Radio
- The GSM network.

Possible equipment levels for remote control and monitoring are detailed in the table below.

The levels correspond to the basic variants. Level 3 includes the control relays, local/remote selector switches and microswitches.

Other documents covering the level of equipment for monitoring (Lvl 1) and integrated remote control & monitoring (Lvl 3) are available on request.

Standard	
Action	Equipment level
No indication at the terminal	0
Indications at a terminal block	1
Indications and motor control at the terminal	2
Signalling and motor control management via the power relays	3
Remote control system with modem - to control and monitor the switchboard via communications systems such as telephones, optical fibre networks, or GSM networks.	4

PE58311



T200 I remote terminal unit

### Easergy T200 I: an interface designed for telecontrol of MV networks

Easergy T200 I is a "plug and play" or multifunction interface that integrates all the functional units necessary for remote supervision and control of the FBX:

- acquisition of the different types of information: switch position, fault detectors, current values...
- transmission of switch open/close orders
- exchanges with the control center.

Required particularly during outages in the network, Easergy T200 I is of proven reliability and availability, being able to ensure switchgear operation at any moment. It is simple to set up and to operate.

#### Functional unit designed for the Medium Voltage network

- Easergy T200 I is designed to be connected directly to the MV switchgear, without requiring a special converter.
- It has an integrated MV network fault current detection system (overcurrent and zero sequence) with detection set points that can be configured channel by channel (current value and fault current duration).
- Open communications thanks to appropriate protocols (IEC101/104, DNP3 or Modbus) and large choice of media (GSM/GPRS, radio, telephone, etc.).
- Automation function with an optional Auto-transfer-switch capability for power source permutation.

#### Medium Voltage switchgear operating guarantee

- It is a backed up power supply which guarantees continuity of service for several hours in case of loss of the auxiliary source, and supplies power to the Easergy T200 I and the MV switchgear motor mechanisms.







---

<b>Fuses</b>	<b>48</b>
Selection of HV fuses	
Selection tables	
<b>1250 A busbar</b>	<b>50</b>
<b>Accessories</b>	<b>51</b>

---

# Fuses

## Selection of HV fuses

### Types of HV fuse

To protect distribution transformers, we recommend that you use HV fuses that have an integrated thermal striker, which is activated at a certain temperature threshold, in compliance with the selection tables. The fuse with thermal striker operates:

- In case of overcurrent
- In case of accidental damage.

It then switches off the switch-disconnector which avoids a thermal overload in the fuse holder.

### Necessary data when placing an order

The following data must be specified:

- Transformer power
- Transformer service voltage.

Rated current of suitable HV fuses is then given by the selection tables. If not applicable, please consult us.

### Technical characteristics

The fuses meet the following standards:

- Protection of the distribution transformers in compliance with the IEC 60787 standard.
- Fuses in compliance with the IEC 60282-1 standard.
- Specifications of the IEC 62271-105 standard.
- Maximum ambient temperature for the switchboards: 40°C in accordance with standards IEC 62271-1. Temperature must be considered when calculating fuse power losses. For higher temperature conditions, please consult us.
- HV fuses can bear 1.3 times the transformer's rated current for a minimum of ten hours.
- The interruption is made at 1.5 times the transformer's rated current for two hours.

### HV fuse

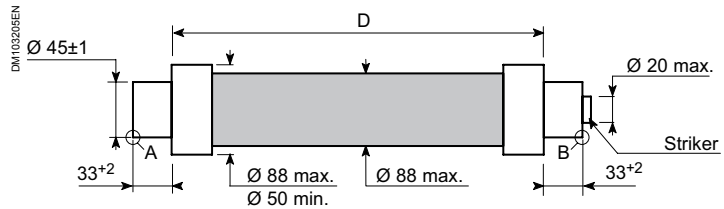

Voltage	D (mm)
Up to 12 kV	292 (with adaptor to extend to 442 mm)
Up to 12 kV	442
17.5 kV	442
24 kV	442

### Spare fuses

Spare fuses must meet the following requirements:

- Dimensions in compliance with technical data sheet 1 (type 1, line 1), IEC 60282-1 publication, radius A and B < 3 mm.
- "Medium" type of striker with a maximum initial tripping force of 80 N.
- When using spare fuses without tripping with a thermal limitation integrated striker, the following requirements must be fulfilled:
  - in case of overcurrents, the interruption must be carried out by LV fuses
  - if the switchboard is installed in an exposed area, in which the fuse links may be submitted to damage due to transient events (e.g. lightning), all the fuses must be replaced in accordance with the appropriate maintenance intervals.

If these requirements are not fulfilled, only the backup HV fuses with integrated tripping of the striker and thermal limitation must be used in the FBX switchboard to protect from a thermal overload.

# Fuses

## Selection of HV fuses

Schneider Electric HV fuses selection table																			
Fusarc-CF type as per IEC		Power of transformer (kVA)																	
		25	50	63	80	100	125	160	200	250	315	400	400	500	630	800	1000	1250	1500
Fuse rated voltage (kV)	Transformer service voltage (kV)	Uk = 4%												Uk = 6%					
		Rated current for fuses (A)																	
7.2	3	10	25	25	31.5	40	50	50	80	100	100 <sup>(2)</sup>	-	-	-	-	-	-	-	-
7.2	3.3	10	25	25	31.5	40	40	50	63	80	100 <sup>(2)</sup>	-	-	-	-	-	-	-	-
7.2	5.5	6.3	16	16	20	25	31.5	31.5	40	50	63	80	80 <sup>(1)</sup>	100 <sup>(1)(2)</sup>	-	-	-	-	-
7.2	6	6.3	10	16	20	25	25	40	40	50	63	80	63	80 <sup>(1)</sup>	100 <sup>(1)(2)</sup>	-	-	-	-
7.2	6.6	6.3	10	16	16	25	25	31.5	40	50	63	63	63 <sup>(1)</sup>	80 <sup>(1)</sup>	80 <sup>(2)</sup>	-	-	-	-
12	10	-	-	10	10	16	20	25	25	31.5	40	50	40	50	63 <sup>(2)</sup>	80 <sup>(1)(2)</sup>	-	-	-
12	11	-	6.3	10	10	16	16	25	25	31.5	40	40	40	63 <sup>(1)</sup>	63 <sup>(1)</sup>	80 <sup>(1)(2)</sup>	-	-	-
24	13.8	4	6.3	6.3	10	10	16	16	20	25	31.5	31.5	31.5	40	50 <sup>(1)(2)</sup>	63 <sup>(1)(2)</sup>	-	-	-
24	15	4	6.3	6.3	10	10	16	20	20	25	31.5	31.5	31.5	40 <sup>(1)</sup>	50 <sup>(1)(2)</sup>	63 <sup>(1)(2)</sup>	-	-	-
24	20	-	-	6.3	6.3	10 <sup>(1)</sup>	10	16	16	20	25	25	25	31.5 <sup>(1)</sup>	40 <sup>(1)</sup>	40 <sup>(1)(2)</sup>	63 <sup>(1)(2)</sup>	-	-
24	22	-	-	6.3	6.3	6.3	10	10	16	16	25	25	25 <sup>(1)</sup>	31.5 <sup>(1)</sup>	40 <sup>(1)</sup>	40 <sup>(2)</sup>	50 <sup>(1)(2)</sup>	63 <sup>(1)(2)</sup>	-

(1) With mechanical time-delay device 70 ms.

(2) Without transformer overload.

Schneider Electric HV fuses selection table																				
Fusarc-CF type as per DIN VDE		Power of transformer (kVA)																		
		25	50	63	80	100	125	160	200	250	315	400	500	630	630	800	1000	1250	1500	1600
Fuse rated voltage (kV)	Transformer service voltage (kV)	Uk = 4%												Uk = 6%						
		Rated current for fuses (A)																		
7.2	6	6.3	10	16	20	25	25	40	40	50	63	80	100	100 <sup>(2)</sup>	100 <sup>(1)(2)</sup>	-	-	-	-	-
12	10	-	-	10	10	16	20	25	25	31.5	40	50	63	80	63 <sup>(2)</sup>	80 <sup>(1)(2)</sup>	-	-	-	-
24	15	4	6.3	6.3	10	10	16	20	20	25	31.5	31.5	50	63	50 <sup>(1)(2)</sup>	63 <sup>(1)(2)</sup>	-	-	-	-
24	20	-	-	6.3	6.3	10 <sup>(1)</sup>	10	16	16	20	25	25	40	40	40 <sup>(1)</sup>	40 <sup>(1)(2)</sup>	63 <sup>(1)(2)</sup>	-	-	-

(1) With mechanical time-delay device 70 ms.

(2) Without transformer overload.

HV fuses (SIBA) selection table with integrated thermal limitation																					
Type Siba HH-DIN		Power of transformer (kVA)																			
		25	50	63	80	100	125	160	200	250	315	400	500	630	630	800	1000	1250	1500	1600	2000
Rated voltage (kV)	Service voltage (kV)	Uk = 4%												Uk = 6%							
		Rated current for fuses (A)																			
7.2	6	-	-	-	-	25	-	40	-	50	63	80	100	125	100	125	160 <sup>(1)</sup>	-	-	-	
12	10	-	-	-	-	16	-	25	-	32	40	50	63	80	63	80	100	100	-	160 <sup>(1)</sup>	160 <sup>(1)</sup>
17.5	15	-	-	-	-	16	-	20	-	32	32	40	50	63 <sup>(1)</sup>	50	63 <sup>(1)</sup>	63 <sup>(1)</sup>	80 <sup>(1)</sup>	-	-	
24	20	-	-	-	-	10	-	16	-	20	25	32	40	40	40	40	50	80 <sup>(3)</sup>	-	100 <sup>(1)(3)</sup>	125 <sup>(1)(3)</sup>

(1) With mechanical time-delay device.

(3) Specific SSK type fuses.

Other HV fuses also available with FBX such as Ferraz fuses or Jean Müller IKUS type fuses.

## Busbar – 1250 A on top of unit

- The top-mounted busbar is used to increase the electrical distribution capacity of the equipment up to 1250 A.
- Available for the following FBX-E functions: C, T1, T2 & CB.
- Increases the standard height of the equipment by 217 mm.
- Two types of LV cabinets are available to fit with 1250 A top busbars: heights of 200 or 600 mm.

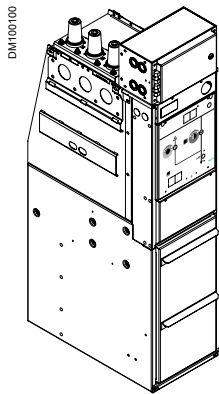

200 mm high LV cabinet for top busbar FBX



View of the busbars

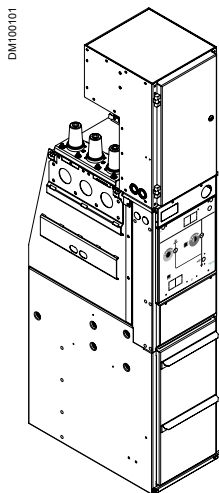

600 mm high LV cabinet for top busbar FBX



Example of an FBX-E on site – configuration C-C-T1-T2-T2-C-C



Relative pressure gauge



Absolute pressure gauge

### Manometer

- The interrupting mechanisms are installed in stainless steel tanks filled with gas. During the service life of the switchboard, the addition of SF6 gas is not necessary.
- The gas pressure in the hermetically sealed tank is indicated, as an option, by a relative or absolute pressure manometer for uses at high altitude.
- An auxiliary contact can be fitted to the manometers (optional).

### Accessories

Standard accessories supplied with FBX switchboard are:

- A set of operating levers
- A set of keys to lock fuse compartment
- In case of motorized mechanisms, an emergency back-up handle.

Ask for details of other supplies. Only Schneider Electric accessories are authorised for use with FBX.

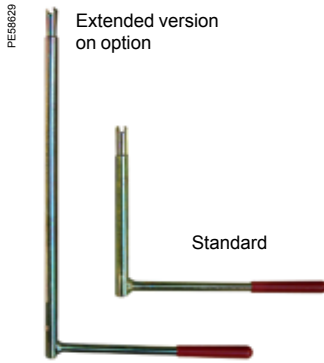

Operating lever for the earthing switch



Operating lever for the CB and CBb circuit-breaker

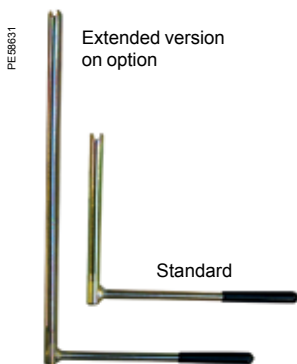

Operating lever for the disconnect, switch disconnect, and T2 circuit-breaker



Key with a double bit



Emergency back-up handle for the motorised control mechanism (optional)



---

<b>Selection of cables</b>	<b>54</b>
<b>Overall dimension drawings</b>	<b>57</b>
<b>Indoor installation</b>	<b>65</b>
<b>Packaging and transport</b>	<b>68</b>

**Cable with synthetic insulation – Single connection per phase for C, T2, CB, R and RE functions**

630 A connector, external cone as per EN 50181, C type connector, screw type contact with M16 x 2 internal threading

Type of cable	Manufacturer	Rated current	12 kV		24 kV	
			Type of connector	For sections in mm <sup>2</sup>	Type of connector	For sections in mm <sup>2</sup>
Complete insulation	EUROMOLD	630	430TB/G	35 - 300	K400LB/G	25 - 300
	EUROMOLD	630	430TB	35 - 300	430TB	35 - 300
	EUROMOLD	630	434TB/G	35 - 300	K400TB/G	35 - 300
	EUROMOLD	630	440TB/G	185 - 630	K440TB/G	185 - 630
	nkt	630	CB 12/630	25 - 300 <sup>(1)</sup>	CB 24/630	25 - 300 <sup>(1)</sup>
	Südkabel	630	SET 12	50 - 300	SET 24	25 - 240
	Südkabel	630	SEHDT 13	300 - 500	SEHDT 23	300 - 630
	Tyco	400	RSES-54xx	25 - 240	RSES-54xx	25 - 240
	Tyco	800	RSTI-58xx	25 - 300	RSTI-58xx	25 - 300
Partially insulated	Tyco	800	RSTI-395x	400 - 800	RSTI-595x	400-800
	nkt	630	AB 12/630	25 - 300	AB24/630	25 - 300
	Tyco	400/630	RICS-51xx with sealing end IXSU-F for one wire cables	25 - 300	RICS-51xx with sealing end IXSU-F for one wire cables	25 - 300
	Tyco	400/630	RICS-51xx with sealing end IXSU-F for three wires cables	25 - 300	RICS-51xx with sealing end IXSU-F for three wires cables	25 - 300
<b>Earthing cable</b>						
Complete insulation	Tyco	400/630	RICS-51xx with sealing end UHGK for belted cables	16 - 300	–	–
	Tyco	400/630	RICS-51xx with sealing end IDST-51xx for cables with one or three paper insulated wires	50 - 300	RICS-51xx with sealing end IDST-51xx for cables with one or three paper insulated wires	35 - 240

<sup>(1)</sup> Sections 300 – 500 mm<sup>2</sup> on request.

Conforming with the manufacturer's technical data and mounting instructions.

**Cable with synthetic insulation - Single connection per phase for T1 transformer protection (250 A)**

250 A connector, external cone as per EN 50181, A type connector, with male contact Ø 7.9 mm

Type of cable	Manufacturer	12 kV		24 kV	
		Type of connector	For sections in mm <sup>2</sup>	Type of connector	For sections in mm <sup>2</sup>
Complete insulation	EUROMOLD	158LR	16 - 120 <sup>(1)</sup>	K158LR	16 - 120 <sup>(1)</sup>
	EUROMOLD	158LR+MC3-158LR-R02	16 - 120 <sup>(1)</sup>	K158LR+MC3-158LR-R02	16 - 120 <sup>(1)</sup>
	EUROMOLD	AGW 10/250	25 - 95	AGW 20/250	25 - 95
	EUROMOLD	AGWL 10/250	25 - 95	AGWL 20/250	25 - 95
	nkt	CE 24-50	25 - 95	CE 24-50	25 - 95
	Südkabel	SEW 12	25 - 150	SEW 24	25 - 95
	Südkabel	–	–	SEHDW 21	120 - 150
	Tyco	RSES-52xx-R	25 - 120	RSES-52xx-R	16 - 120

<sup>(1)</sup> 150 mm<sup>2</sup> on request.

Conforming with the manufacturer's technical data and mounting instructions.

Note: All the above connector selection are based on the standard FBX (Height:1380mm). Please consult us for the selection for FBX with low cable compartment (Height:1040mm)



**Cables with synthetic insulation - Double connection per phase for C, R, RE functions**

630 A connector, external cone as per EN 50181, C type connector, screw type contact with M16 x 2 internal threading

Type of cable	Manufacturer	Rated current	12 kV		24 kV	
			Type of connector	For sections in mm <sup>2</sup>	Type of connector	For sections in mm <sup>2</sup>
Complete insulation	EUROMOLD	630	434 TB/G + 300 PB	300 - 630	434 TB/G + 300 PB	300 - 630
	EUROMOLD	630	430 TB + 300 PB	35 - 300	430 TB + 300 PB	35 - 300
	nkt <sup>(1)</sup>	630	CB 12/630 + CC 12/630	25 - 300	CB 24/630 + CC 24/630	25 - 300
	Südkabel	630	SET 12 + SEHDK 13.1	70 - 300	SET 24 + SEHDK 23.1	35 - 240
	Tyco	800	RSTI-58xx + RSTI-CC-58xx	25 - 300	RSTI-58xx + RSTI-CC-58xx	25 - 300
Partially insulated	nkt	630	AB 12/630 + AC 12/630	25 - 300	AB 24/630 + AC 24/630	25 - 300
	Tyco	400/630	RICS-57xx with sealing end IXSU-F for one wire cables + RICS-51xx with sealing end IXSU-F for one wire cables	25 - 300	RICS-57xx with sealing end IXSU-F for one wire cables + RICS-51xx with sealing end IXSU-F for one wire cables	25 - 300
	Tyco	400/630	RICS-57xx with sealing end IXSU-F for three wires cables + RICS-51xx with sealing end IXSU-F for three wires cables	25 - 300	–	–
<b>Earthing cable</b>						
Partially insulated	Tyco	400/630	RICS-57xx with sealing end IDST-57xx for cables with one or three paper insulated wires	50 - 300	–	–

*(1) Obligatory for the IAC 25 kA option**The second cables mounting support must be specified when ordering the FBX.**A surge arrester may be installed instead of a second cable connection. These mounting supports are available on request. Conforming with the manufacturer's technical data and mounting instructions.***Cables with synthetic insulation - Triple connection per phase for C, R and RE functions**

630 A connector, external cone as per EN 50181, C type connector, screw type contact with M16 x 2 internal threading

Type of cable	Manufacturer	Rated current	12 kV		24 kV	
			Type of connector	For sections in mm <sup>2</sup>	Type of connector	For sections in mm <sup>2</sup>
Complete insulation	nkt	630	CB 12/630 + CC 12/630	25 - 300	CB 24/630 + CC 24/630	25 - 300

*Note: the IAC 25 kA option is not available if 3 cables are used per phase.**The cables mounting support must be specified when ordering the FBX.**A surge arrester may be installed instead of a third cable connection. These mounting supports are available on request. Conforming with the manufacturer's technical data and mounting instructions.*

**Cable with synthetic insulation - Single connection per phase with surge arrester for C, T2, CB**

630 A connector, external cone as per EN 50181, C type connector, screw type contact with M16 x 2 internal threading

			12 kV		24 kV	
Type of cable	Manufacturer	Rated current	Type of connector	For sections in mm <sup>2</sup>	Type of connector	For sections in mm <sup>2</sup>
Complete insulation	nkt	630	CB 12/630 + CC 12/630	25 - 300	CB 24/630 + CC 24/630	25 - 300
	EUROMOLD	630	430 TB + 300 SA	35 - 300	430 TB + 300 SA	35 - 300
	Südkabel	630	SET 12 + MUT 23	50 - 300	SET 24 + MUT 23	25 - 240
	Südkabel	630	SEHDT 13.1 + MUT 23	70 - 300	SEHDT 23.1 + MUT 23	35 - 240
	Tyco	800	RSTI-58xx + RSTI-CC-58SAxx05 (5 kA) RSTI-58xx + RSTI-CC-66SAxx10 (10 kA)	25 - 300	RSTI-58xx + RSTI-CC-58SAxx05 (5 kA) RSTI-58xx + RSTI-CC-66SAxx10 (10 kA)	25 - 300
	Tyco	800	RSTI-395x + RSTI-CC-58SAxx05 (5 kA) RSTI-395x + RSTI-CC-66SAxx10 (10 kA)	25 - 300	RSTI-595x + RSTI-CC-58SAxx05 (5 kA) RSTI-595x + RSTI-CC-66SAxx10 (10 kA)	400 - 800
Partially insulated	Tyco	400/630	RICS-57xx with sealing end IXSU-F for one wire cables + RICS-51x9 plus RDA-xx	25 - 300	RICS-57xx with sealing end IXSU-F for one wire cables + RICS-51x9 plus RDA-xx	25 - 300
	Tyco	400/630	RICS-57xx with sealing end IXSU-F for three wires cables + RICS-51x9 plus RDA-xx	25 - 300	–	–
<b>Earthing cable</b>						
Partially insulated	Tyco	400/630	RICS-51xx with sealing end IDST-51xx for cables with one or three paper insulated wires	50 - 300	–	–

**Cable with synthetic insulation – Double connection per phase for T2, CB functions**

630 A connector, external cone as per EN 50181, C type connector, screw type contact with M16 x 2 internal threading

			12 kV		24 kV	
Type of cable	Manufacturer	Rated current	Type of connector	For sections in mm <sup>2</sup>	Type of connector	For sections in mm <sup>2</sup>
Complete insulation	nkt	630	CB 12/630 + CC 12/630	25 - 300	CB 24/630 + CC 24/630	25 - 300
	Tyco	800	RSTI-58xxx + RSTI-CC-58xx	25 - 300	RSTI-58xx + RSTI-CC-58xx	25 - 300
	Südkabel	630	SEHDT 13	300 - 500	SEHDT 23	300 - 630
Partially insulated	nkt	630	AB 12/630 + AC 12/630	25 - 300	AB 24/630 + AC 24/630	25 - 300
	Tyco	400/630	RICS-57xx with sealing end IXSU-F for one wire cables + RICS-51xx with sealing end IXSU-F for one wire cables	25 - 300	RICS-57xx with sealing end IXSU-F for one wire cables + RICS-51xx with sealing end IXSU-F for one wire cables	25 - 300
	Tyco	400/630	RICS-57xx with sealing end IXSU-F for three wires cables + RICS-51xx with sealing end IXSU-F for three wires cables	25 - 300	–	–
<b>Earthing cable</b>						
Partially insulated	Tyco	400/630	RICS-57xx with sealing end IDST-57xx for cables with one or three paper insulated wires	50 - 300	–	–

## FBX-C, 3 functions switchboard C-C-T1 configuration

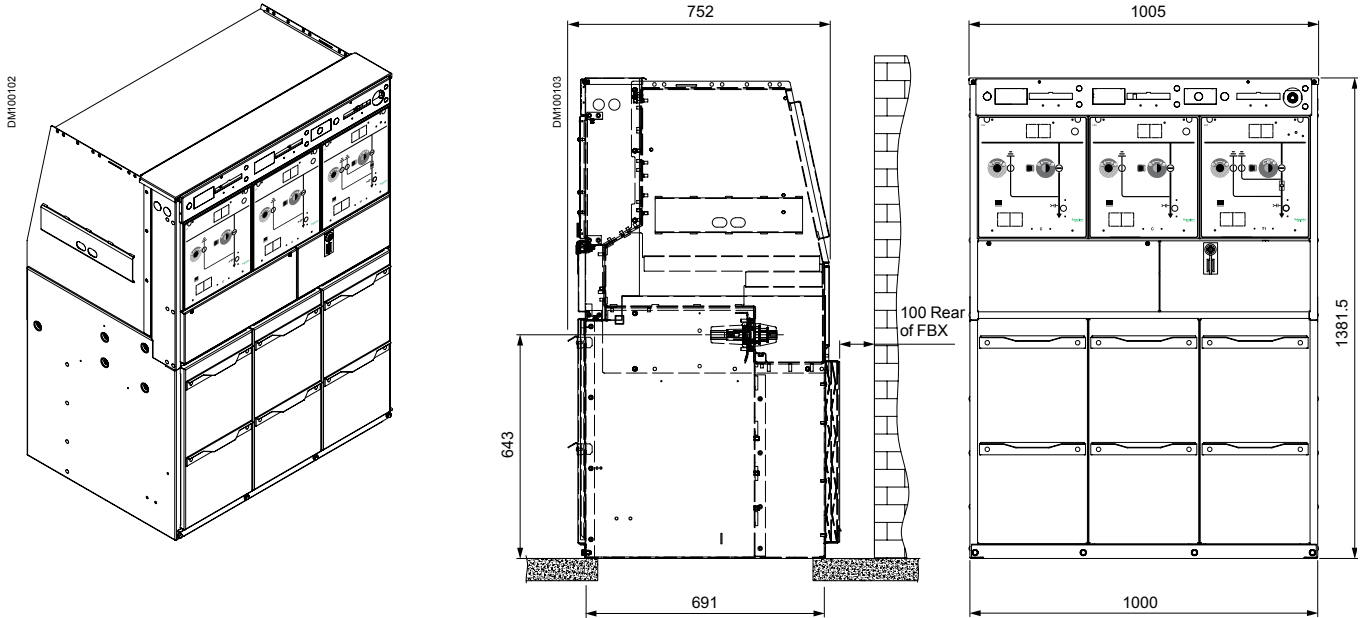

### Cable compartment dimensions

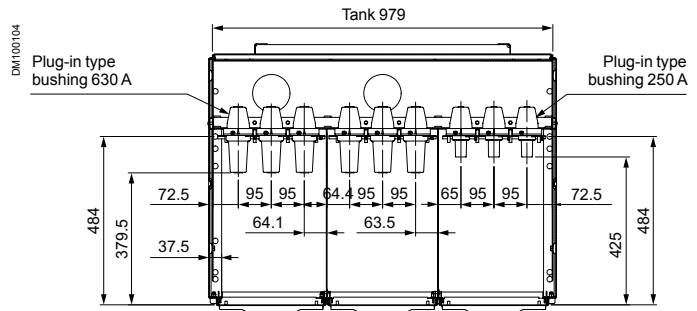

## FBX-C, 4 functions switchboard C-T1-C-T1 configuration

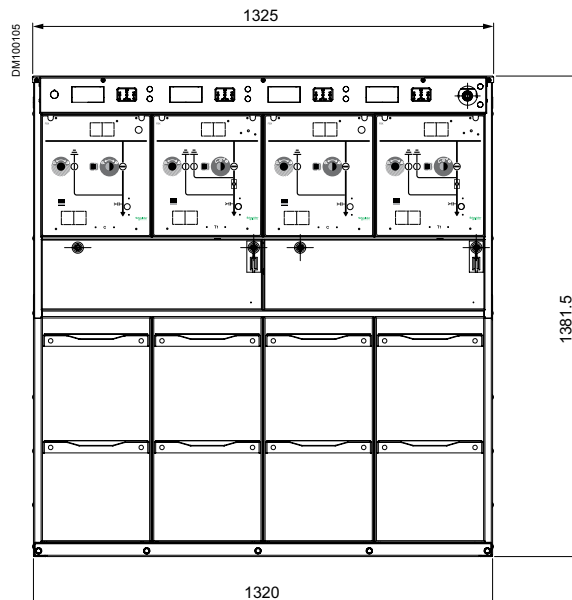

## FBX-C, 3 functions switchboard C-C-T2 configuration

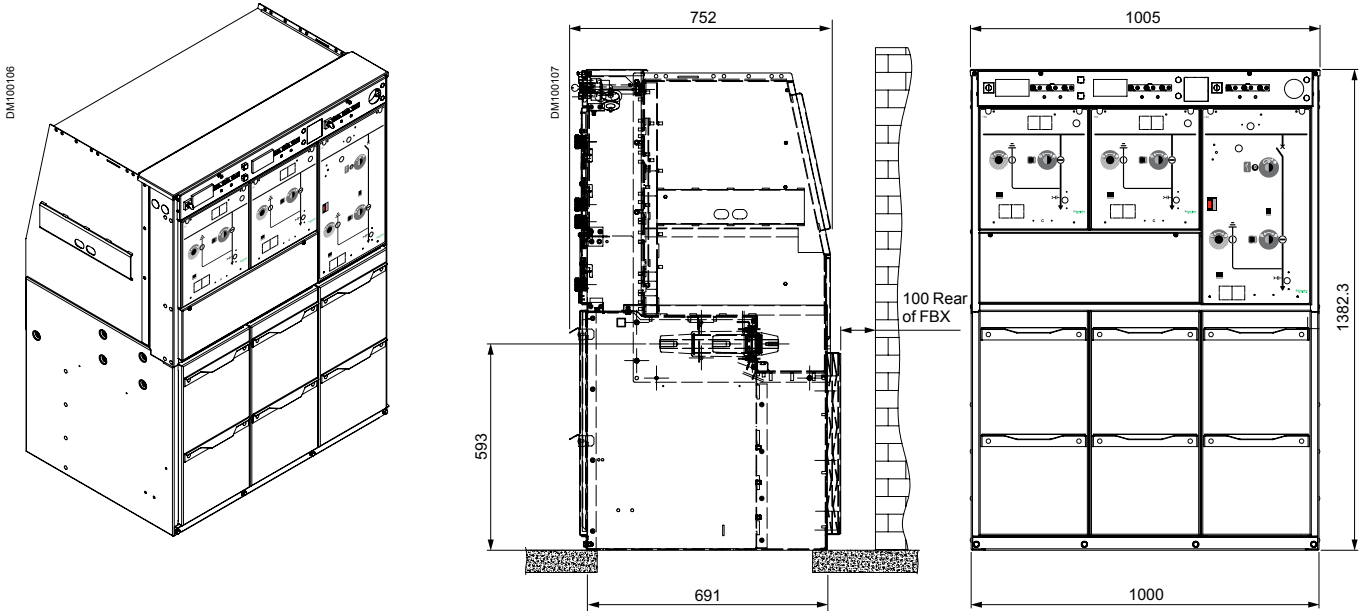

### Cable compartment dimensions

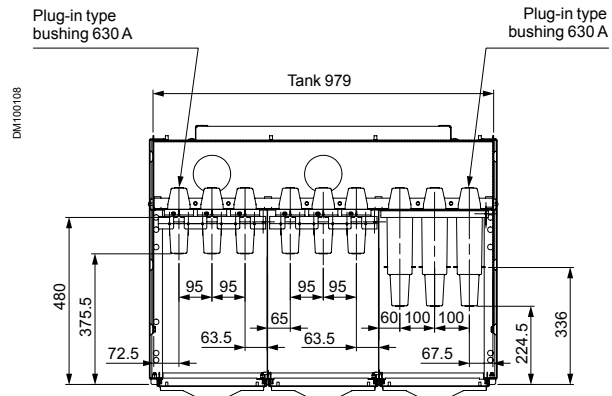

## FBX-C, 4 functions switchboard C-C-C-T2 configuration

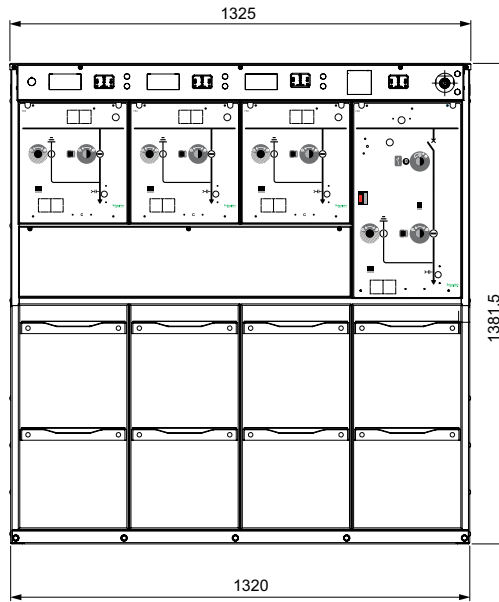
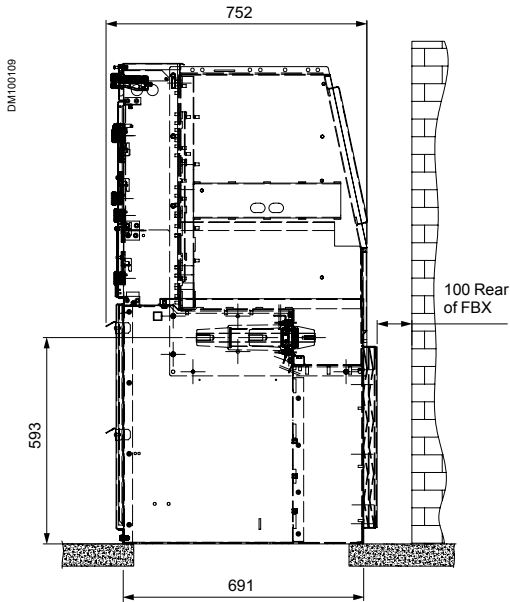

### Cable compartment dimensions

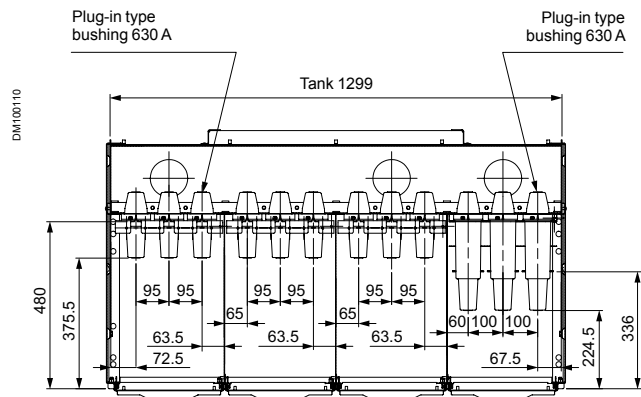

## FBX-E, 4 functions switchboard C-C-T1+C configuration

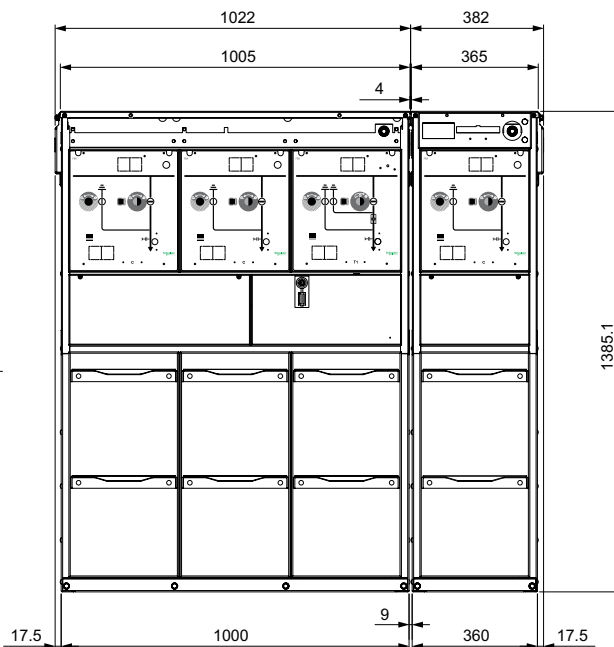
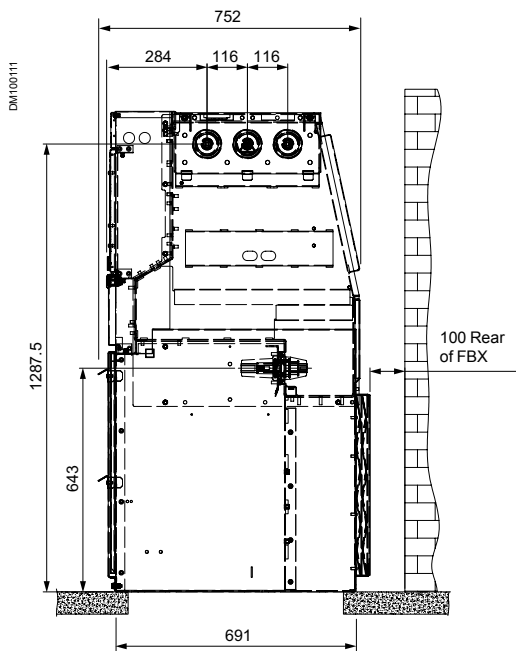

### Cable compartment dimensions

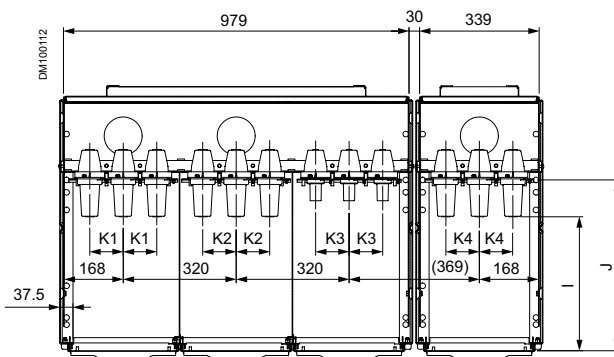

K = 95 mm  
 I = 381 mm (400 A)  
 379.5 mm (630 A)  
 J = 484 mm

A minimum of 450 mm is required to install an extension unit to a FBX-E.

## FBX-E, 1 function switchboard T1 configuration

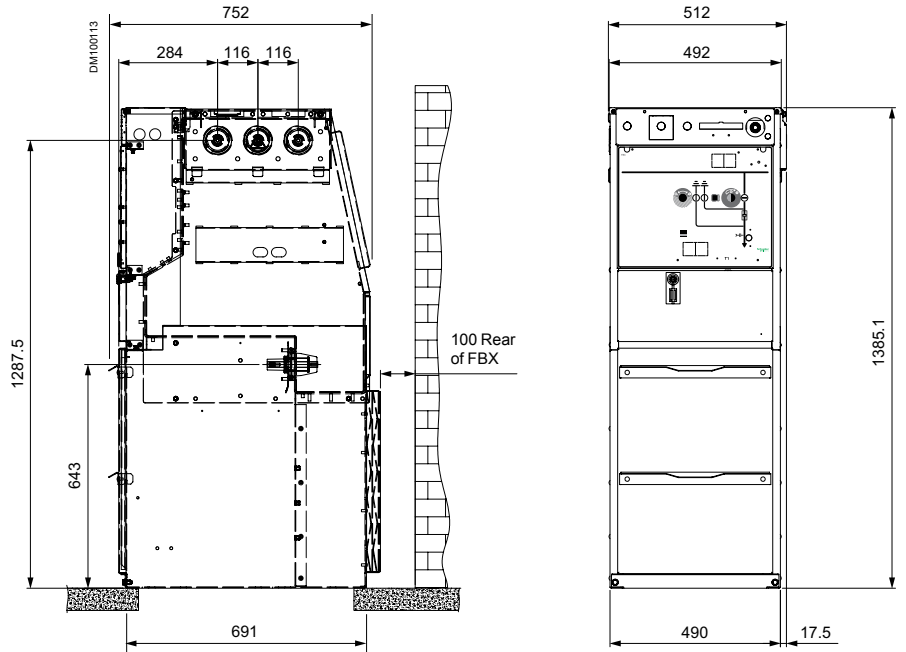

### Cable compartment dimensions

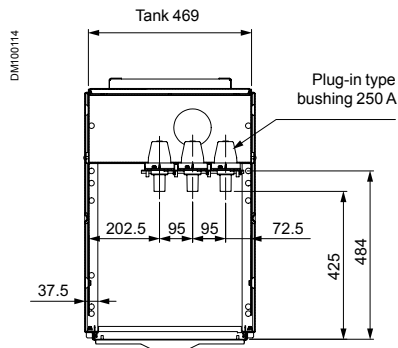

## FBX-E, 1 function switchboard T2 configuration

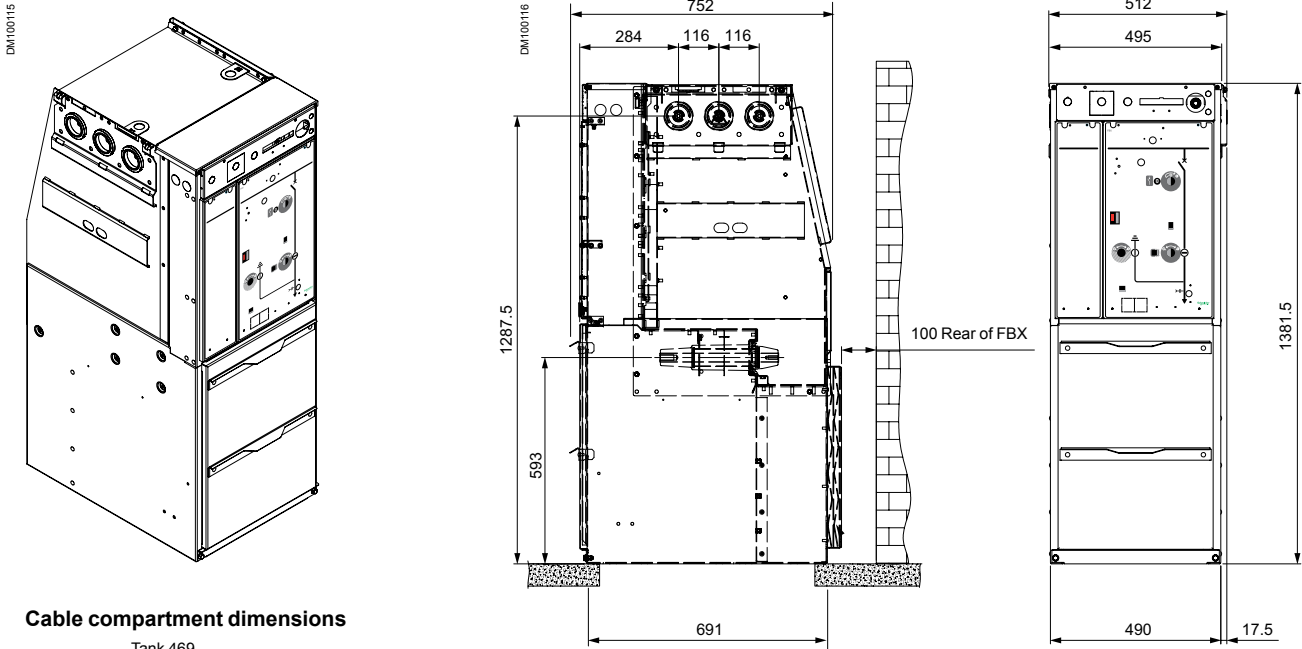

### Cable compartment dimensions

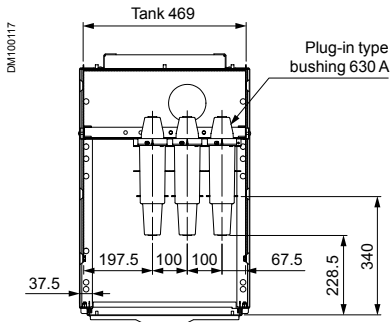

## FBX-E, 1 function switchboard T2 + LV cabinet (600 mm) configuration

### T2 with 200 mm LV cabinet

### T2 with 600 mm LV cabinet

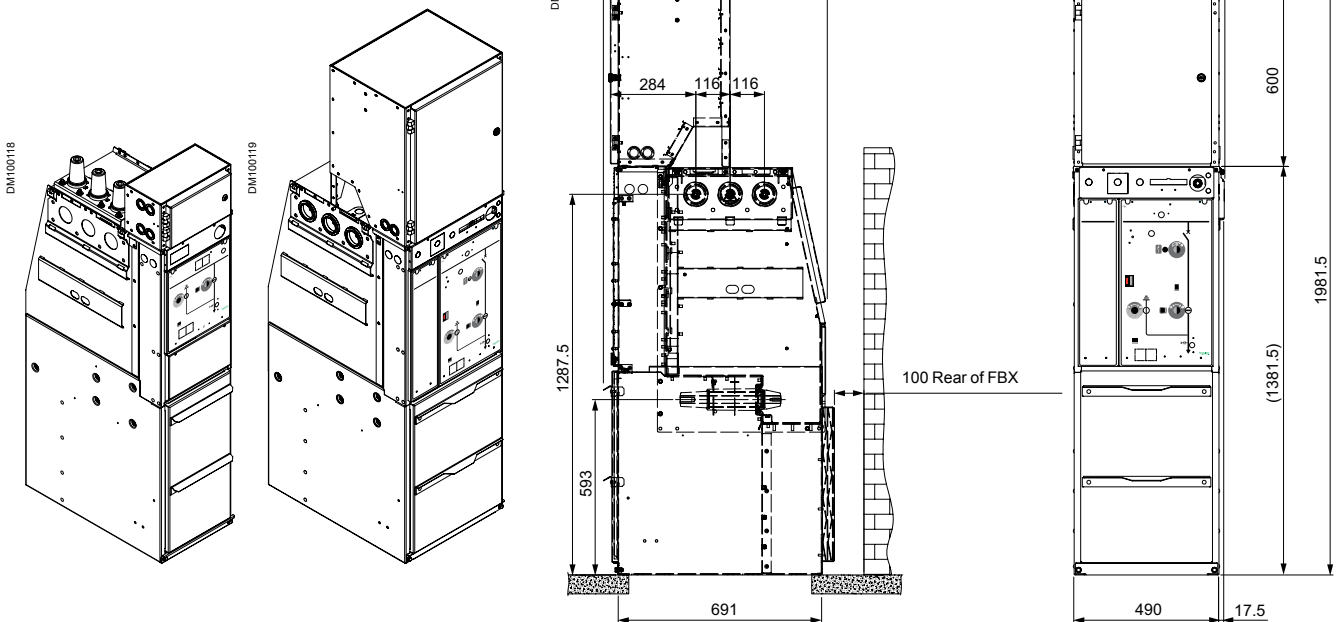



## FBX-E, 1 function switchboard CB configuration

DM103199

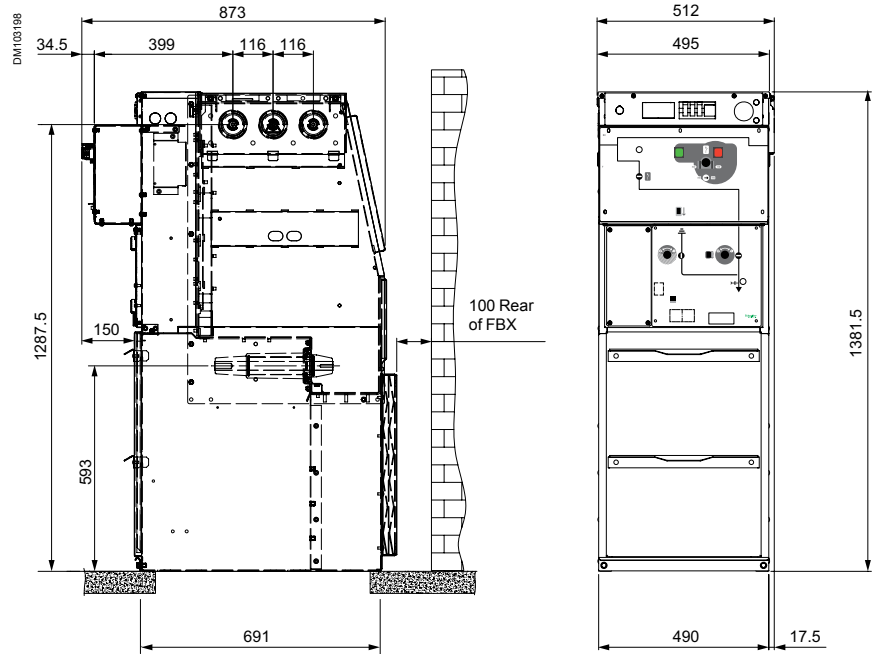
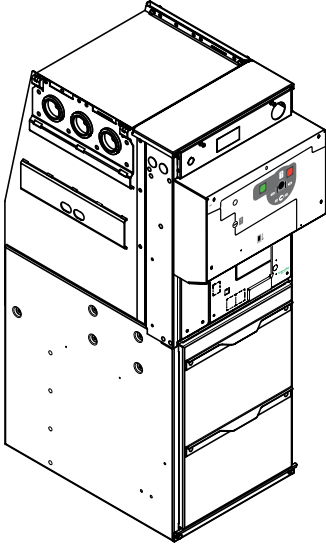

### Cable compartment dimensions

DM100723

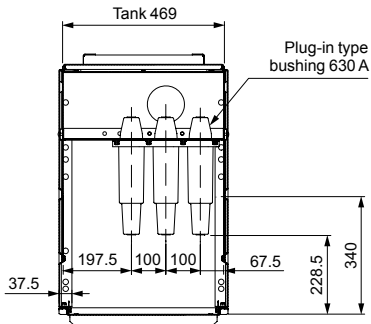

## FBX-E, 1 function switchboard CBb configuration

DM103201

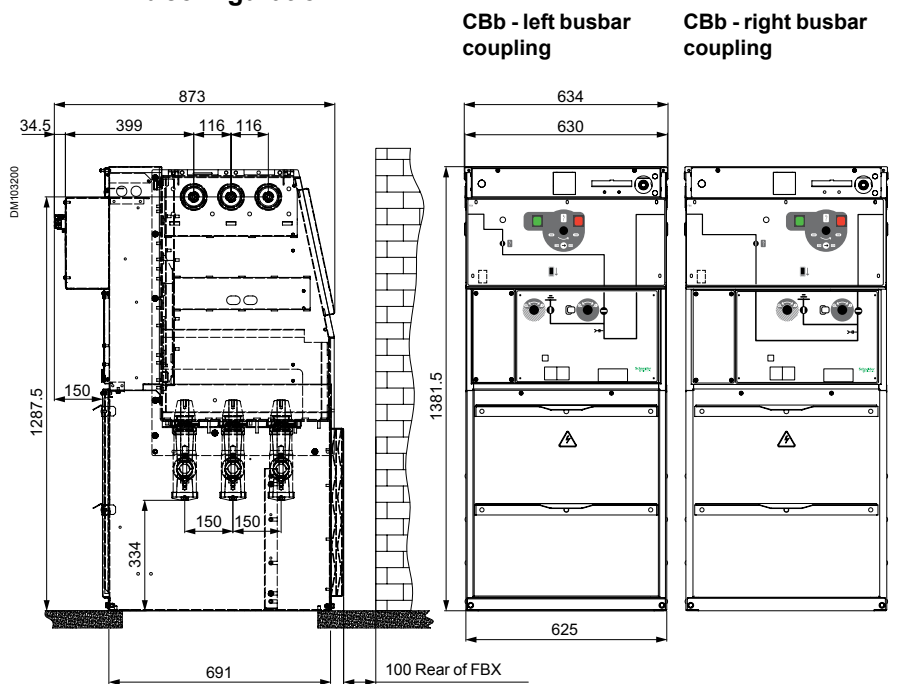
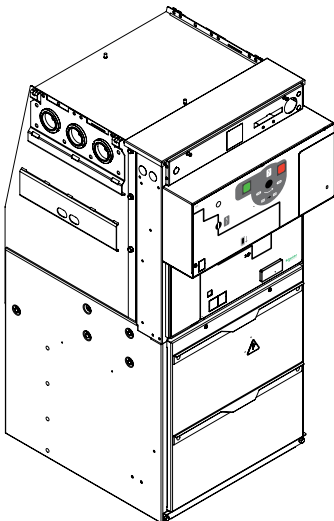

## Metering cubicles

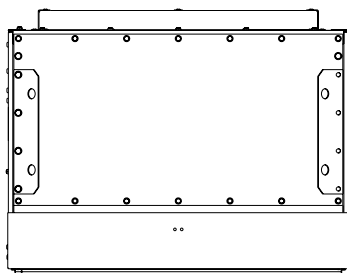
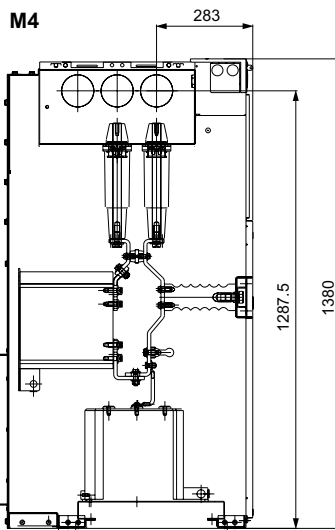
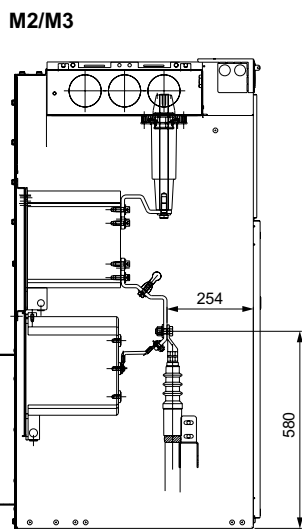
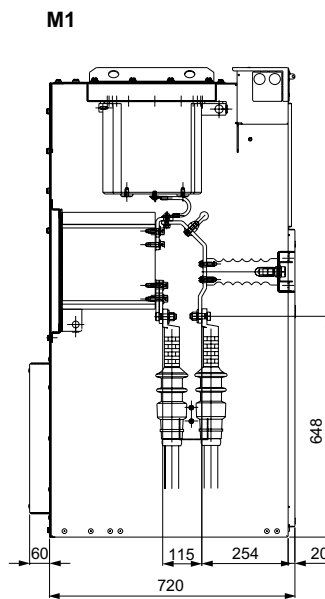
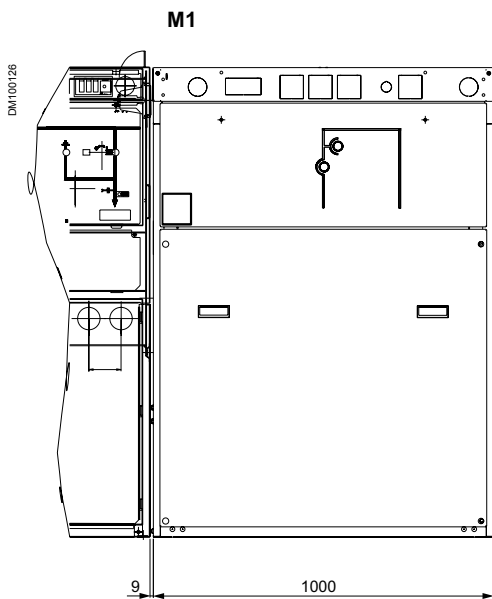

Fixing points

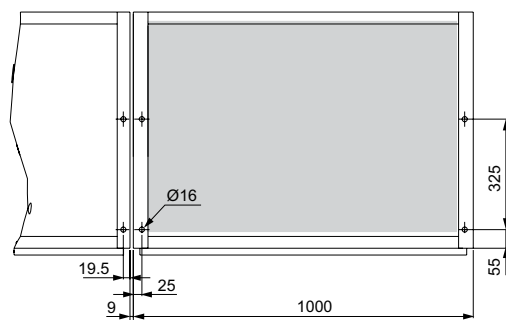

## Minimum distances between the FBX-E and the building's walls

Top view

Functions and distances		Space (mm)	
<b>A</b>	Unit 1 function M1, M2, M3, M4	1000	
	Unit 2 functions	680	
	Unit 3 functions	1000	
	Unit 4 functions	1320	
<b>B</b>	Unit 1 function C, R, RE	360	
	Unit 1 function T1, T2, CB	490	
	Unit 1 function CBb	625	
<b>C</b>	Distance with the side wall of the building for extensions at the extremity of the switchboard	450	
<b>D</b>	Distance between the rear of the switchboard and the building's wall	Release of overpressures only towards the bottom Release of overpressures towards the top and the rear	100 100/140
	<b>E</b>	Minimum width of passage in front of the FBX-E switchboard: the national standards/ instructions must be respected! For a subsequent extension to the existing FBX-E: access for assembly E > 950; FBX-C: > 800	

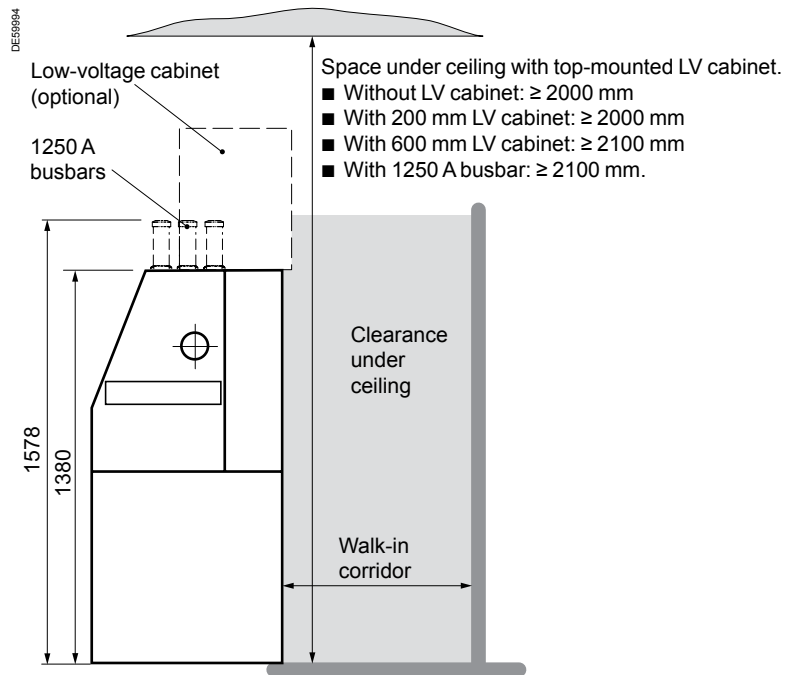
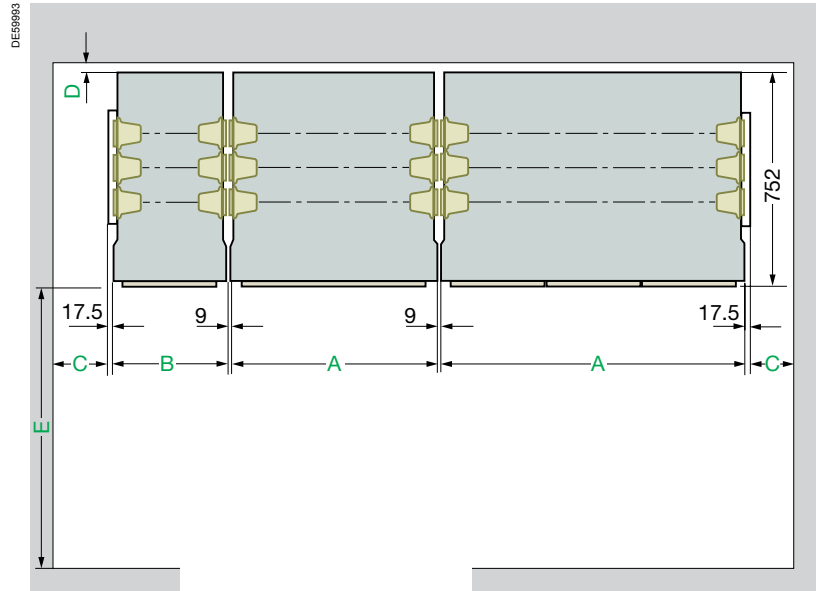

## Indoor installation & evacuation of overpressures

We are presenting several examples of installation for transformer substations (IAC classification as per IEC 62271-200).  
For further information, consult the civil engineering guide.

Example of an FBX-C C-C-T1 installation:

Height of the room  $\geq 2,000$  mm with possible solutions for the evacuation of gases in case of overpressure.

With rear deflector



■ IAC class AF 16/20 kA 1s

With rear deflector

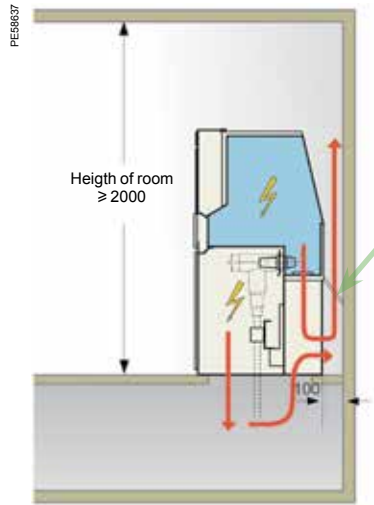

→: Evacuation of gas in the event of overpressure

■ IAC class AF 16/20 kA 1s

With gas cooler

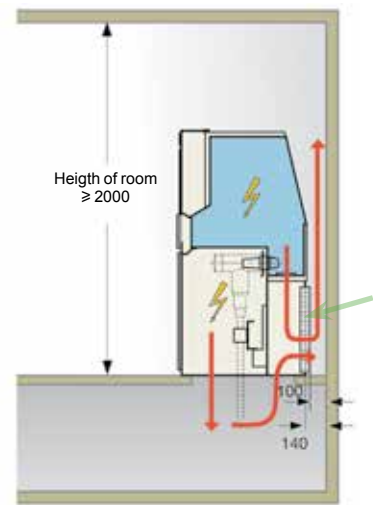

→: Evacuation of gas in the event of overpressure

With double side panel



■ IAC class AFL 16/20 kA 1s

With side panel

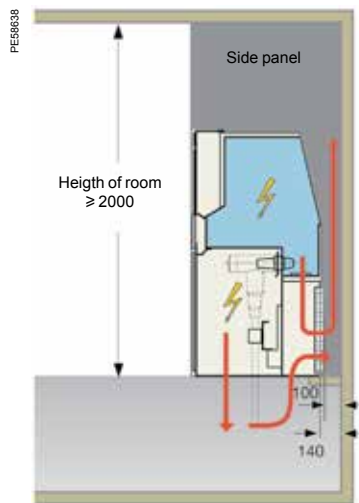

→: Evacuation of gas in the event of overpressure

■ IAC class AFL 16/20 kA 1s

With side panel

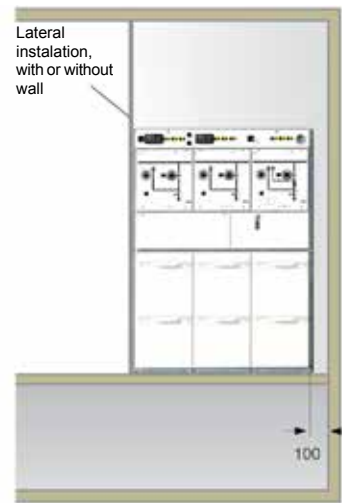

Example of an installation for transformer substations without cable trough or double panel (IAC classification as per IEC 62271-200).

Example of FBX installation where the exhaust of gas goes into cable duct and through a gas cooler made of 5 layers of metal.

With mounting base and gas exhaust duct



■ IAC class AFL 16/20 kA 1s

With chimney and base

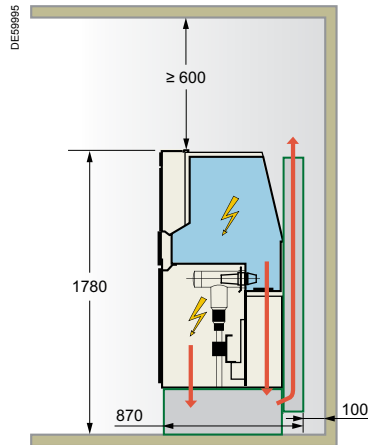

→: Evacuation of gas in the event of overpressure

■ IAC class AFL 16/20 kA 1s

Without side panel

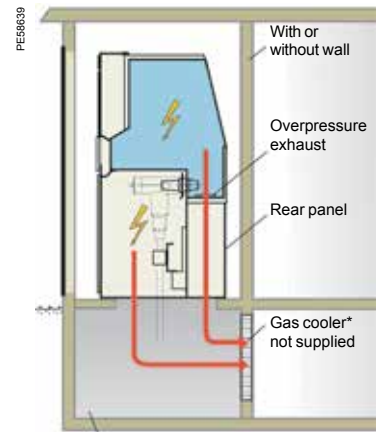

\* Duct cross section > 0.3 m<sup>2</sup> at 16 and 20 kA

→: Evacuation of gas in the event of overpressure

## Packaging

- For road and rail transport:  
 FBX switchboard is packaged under protective sheeting. It is delivered fixed on to a wooden pallet by two plastic tapes.
- For maritime transport:  
 FBX is packaged in a heat-sealed cover with bags of desiccant, then enclosed in a wooden case with a solid leaktight bottom (including transport by container).
- For air transport:  
 FBX switchboard is packaged in a wooden boxes (crates) with solid walls and a protective cover (dust cover).

## Handling

- The FBX must be transported vertically:
- When moving using a forklift:  
 Only move the device on a pallet.
  - When moving without a pallet:  
 A lifting sling must be hooked on to the switchboard's lifting rings. The angle with the lifting sling must be at least 45°.
  - When transporting a switchboard:  
 Maximum width of transport unit: 1330 mm.

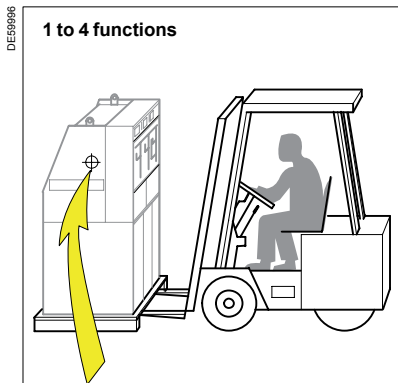

**⚠** When transporting on a pallet, do not tilt the switchboard. Respect the centre of gravity markings.

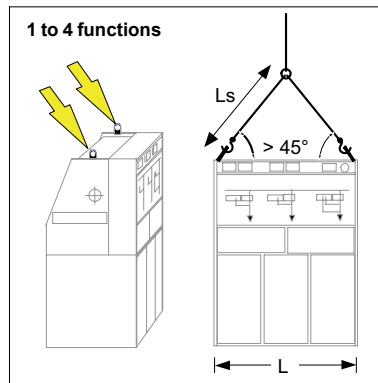

**⚠** When transporting with slings, use the two lifting rings.

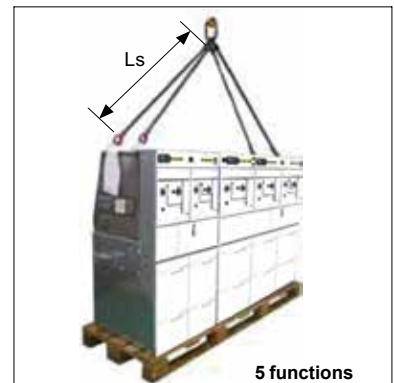

**⚠** This switchboard can be transported:  
 ■ either using slings, attached to the 4 lifting rings  
 ■ or, by two hand trolleys, one at either end.

Switchboard with LV cabinet	Number of functions	Composition of the switchboard	Width X (mm) from the swing arm
	1	C/RE/R	370
	1	T1/T2/CB	500
	2	All types, except T1-T1/T2-T2	690
	2		990
	3	All types	1010
	4	All types	1330
	5	C-C-C-C-C/C-C-C-C-T1/C-C-C-T1-T1	1685
	5	C-T1-C-T1-T1	1815

## Storage

FBX must be packaged depending on the requirements for its planned storage duration. FBX must be preserved intact in its factory origin packaging. The storage area must not have any sharp and important changes in temperature. Consult us for any particular storage condition.

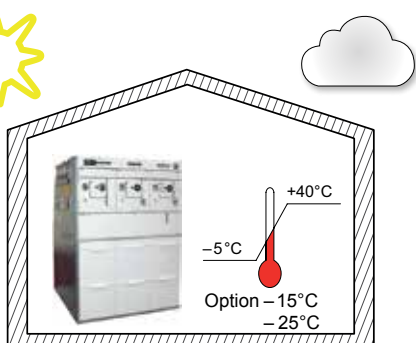

DE59897







---

<b>Schneider Electric Services</b>	<b>72</b>
<b>ProDiag Corona</b>	<b>73</b>
<b>ProDiag Fuses</b>	<b>74</b>



**Plan**

Schneider Electric helps you to plan the full design and execution of your solution, looking at securing your process and optimising your time:

- **Technical feasibility studies:** Accompany customer to design solution in his given environment.
- **Preliminary design:** Accelerate turn around time to come to a final solution design.

**Install**

Schneider Electric will help you to install efficient, reliable and safe solutions based on your plans.

- **Project Management:** Designed to help you complete your projects on time and within budget.
- **Commissioning:** Ensures your actual performance versus design, through on site testing & commissioning, tools & procedures.

**Operate**

Schneider Electric helps you maximise your installation uptime and control your capital expenditures through its services offering.

- **Asset Operation Solutions:** The information you need to increase safety, enhance installation training performance, and optimise asset maintenance and investment.
- **Advantage Service Plans:** Customised services plans which cover preventive, predictive and corrective maintenance.
- **On site Maintenance services:** Extensive knowledge and experience in electrical distribution maintenance. For Diagnosis services see on pages from F1 to F3.
- **Spare parts management:** Ensure spare parts availability and optimised maintenance budget of your spare parts.
- **Technical Training:** To build up necessary skills and competencies. in order to properly operate your installations in safety.

**Optimise**

Schneider Electric propose recommendations for improved safety, availability, reliability & quality.

- **MP4 Electrical Assessment:** Define improvement & risk management program.

**Renew**

Schneider Electric extends the life of your system while providing upgrades. Schneider Electric offers to take full responsibility for the end-of-life processing of old electrical equipments.

- **ECOFIT™:** Keep up to date & improve performances of your electrical installations (LV,MV, Protection Relays...).
- **MV product End of life:** recycle & recover outdated equipment with end of life services.

**Frequency of maintenance intervention**

Schneider Electric equipment manufacturers recommend a schedule for maintenance activities to extend Electrical Distribution equipment performance over time. Frequencies under normal/healthy operation (minor equipment criticality and optimal environmental conditions) can be generally defined as follows:

Maintenance	Minimal frequency <sup>(1)</sup> (every)	Who		
		Manufacturer	Certified partner	End user
Exclusive	4 years	■		
Advanced	2 years	■	■	
Light	1 year	■	■	■

*(1) Recommended under normal operating conditions (minor equipment criticality and optimal environmental conditions). However, this recommended frequency should be increased according to: a) the level of criticality (low, major, critical) b) the severity of environment conditions (i.e. corrosive, naval, offshore) following recommendations of Manufacturer's services.*

**When it comes to your electrical distribution installation, we can help you:**

- Increase productivity, reliability, and safety
- Mitigate risk and limit downtime
- Keep equipment up to date and extend lifespan
- Cut cost and increase savings
- Improve your return on investment

**Contact us!**

[www.schneider-electric/electricaldistributionservices](http://www.schneider-electric/electricaldistributionservices)

# ProDiag Corona

## Diagnostics of partial discharges



### What is ProDiag Corona?

**ProDiag Corona** is a Schneider Electric diagnosis tool.

**ProDiag Corona** detects partial discharges in Medium Voltage cubicles.

- Partial Discharge occurs across part of the insulation between two conducting electrodes, without completely bridging the gap.
- Partial discharge can happen under normal working conditions as a result of insulation breakdown due to premature aging caused by thermal or electrical over-stressing of the high voltage system.

**ProDiag Corona** analyses the primary electrical signal through VIS (Voltage Indicator System) fixed on the switchboards. Measurements are taken by an electronic sensor and the data is transmitted to the ProDiag Corona software in order to evaluate the level of criticality of the controlled equipment.

A written report is generated, which will be handed over by Schneider Electric so that the customer can use it as a tool to define the necessary corrective action, whether maintenance, repair or replacement.

**ProDiag Corona** is not a certification tool.

**ProDiag Corona** executes the assessment of the energized equipment, without any shutdown and then without disruption for the users.

This system allows you to control all types of the most common partial discharges:

- Internal partial discharges
- Surface partial discharge
- Corona effect

ProDiag Corona diagnostic can be realized on most Medium Voltage equipment on the market equipped with VIS.

### Where can ProDiag Corona reduce costs?

ProDiag Corona significantly reduces the time taken to identify potential faults in a switch, without electrical shutdown.

A device's normal operating life is increased by timely diagnostics of when and what repairs are necessary. ProDiag Corona is a trouble shooting anticipation tool which can avoid internal arc risks and untimely tripping.

- The tool comprises both hardware and software, resulting in a highly efficient preventive maintenance program.

### Results

**ProDiag Corona** provides a report of the complete electrical room, detailing: ventilation, air filtration, due point calculation, level of criticality of each set of equipment, constructor recommendations on any potential maintenance, repair & rehabilitation.

This report enables any required maintenance to be targeted and timed to optimize the customer's maintenance plan.

ProDiag Corona is performed thanks to XDP2 testing equipment from NDB technology

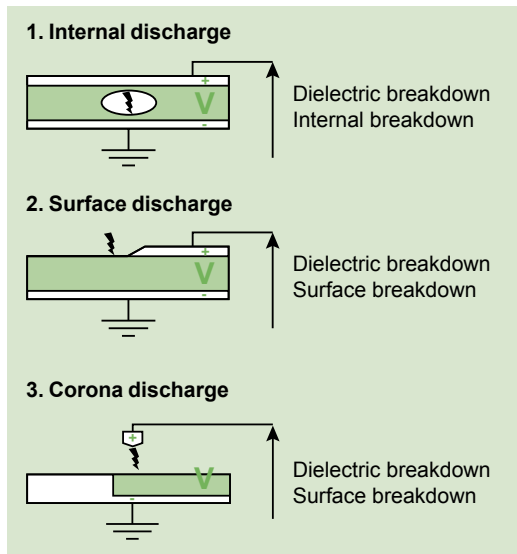

### ProDiag Corona objectives

#### Safety (Human Life and asset)

- Enhance the reliability of your installation
- Optimisation of installation life duration & costs

#### Risks prevention from:

- Partial discharges and internal arc
- Dielectric degradation
- Electrical Fire

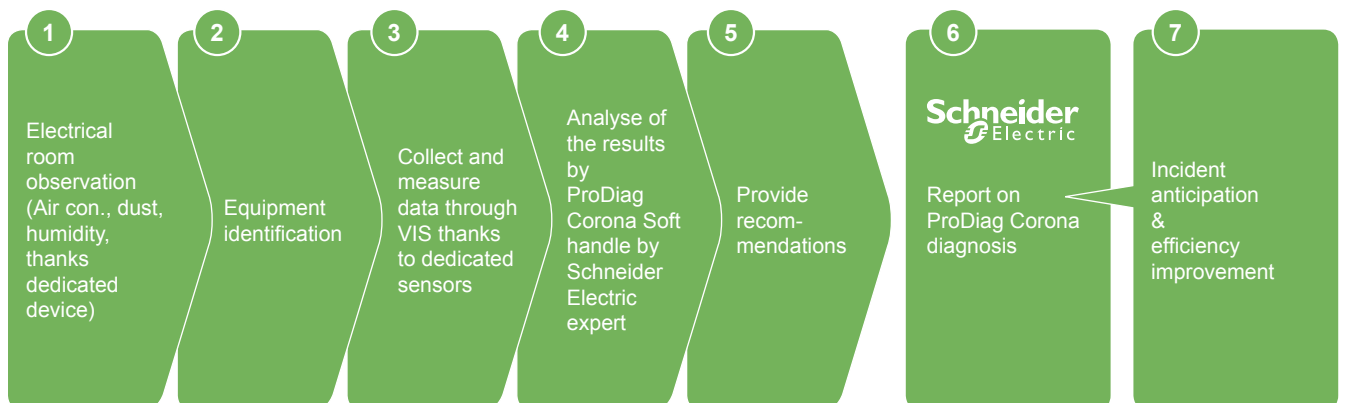

# ProDiag Fuses

## Proprietary and standards diagnostics tools



### Customer needs

Electrical power installations protected by MV switchgear with fuse protection should be regularly checked (for correct assembly, electrical parameters, etc.) to confirm that their characteristics correspond to the original specification. Regular diagnosis of fuse performance (electrical parameters, resistance) according to the manufacturer's recommendations is necessary to secure the ED installation and its service continuity, which are important for customers. The ProDiag Fuse diagnostic solution can be used on MV switchgear protected by fuses that have not received any maintenance intervention in the last four years (under normal operating conditions, and less if operating in severe environments or depending on their criticality in the installation).



The purpose of ProDiag Fuse (a proprietary hardware-software solution) is to mitigate the risks on MV switchgear and equipment by fuses of faults or drifts causing unwanted effects. The result of fuse ageing is the destruction of filaments that can lead to thermal runaway, partial damage, complete destruction of MV switchgear and equipment, or even destruction of the electrical room.

### Customer benefits

ProDiag Fuse helps customers visualise, discover, and understand MV switchgear fuse ageing and wear and tear as compared to the original fuse manufacturers' technical specification.

ProDiag Fuse monitors the performance of MV switchgear fuses. Thanks to ProDiag Fuse, maintenance managers can implement, manage, and enrich their maintenance plans. Schneider Electric FSRs conclude their on-site interventions with an exhaustive report on the MV switchgear fuses conformity/non-conformity. If a MV fuse is declared non-conforming, Schneider Electric suggests a corrective plan that includes fuse replacement to regain original performance in safety and service continuity.

Customers can augment their preventive maintenance plans with this corrective action at the most convenient time for each ED device.

### "Unique value for customer vs standard market tools"

Electrical parameter measurements (resistance, etc.) on MV switchgear fuses at customer sites are taken by a test tool and transmitted to the Schneider Electric FSRs' ProDiag Fuse software. Data are compared to those of a fuse manufacturers' technical database.

The aim is to determine whether recorded measurements are within the acceptable range, at the limit, or fall outside it, as criteria for MV switchgear fuse conformity.

As an ED equipment manufacturer, Schneider Electric is uniquely positioned to develop and invest in specific tests tools, proprietary software, and testing methodology to collect reliable measurements from MV switchgears fuses.

ProDiag Fuse measures a larger number of parameters than standard market tools. It delivers best-in-class MV switchgear fuse diagnostics.

**Schneider Electric scope:** Schneider Electric fuses and main market fuses players.





---

<b>Sustainable development</b>	<b>78</b>
<b>End of service life processing</b>	<b>79</b>

---

PE89647



Schneider Electric has resolved to engage itself in a dynamic process of sustainable development through 6 commitments:

- To develop eco-design to reduce environmental impact of the products during their lifetime
- To reduce greenhouse effect gases related to SF6
- To develop environmental management and safety
- To participate in the local economy
- To develop a responsible purchasing policy
- To minimise impact on the environment by offering solutions allowing for renewable energies to be connected to electrical networks.

### Eco-design and impact on the environment

Schneider Electric contributes efficiently to worldwide savings in terms of energy resources.

FBX replies to a high degree of ecological requirements related to environmental protection thanks to:

- The optimisation of consumption of materials and energy during manufacture
- The compliance with all ecological requirements during the service life of the product
- The use of materials that can be recycled for an efficient valorisation.

### A responsible design

Our construction directives relating to an ecological design specify the use of materials that are easy to recycle and dismantle:

- 90% of the metals of a switchboard (CCT1 type) can be recycled, as well as
- all thermosetting plastics and thermoplastics.

All the materials have been selected and developed in such a way that, for instance, a switchboard affected by a fire in a building has a minimal impact on the load of the fire (development of heat and toxic substances in the emissions).

Eco-declarations are available on request.

### Environmental impact

The end of service life phase is considered a very important part of the life cycle of Schneider Electric products. The environmental impact inherent to the disposal of equipment is sometimes more polluting than the manufacturing, delivery or use. European directives, such as WEEE, ELV and RoHS, have confirmed this point and all insist upon the recovery of waste products and their valorisation at the end of the equipment's service life.

Even though our switchgear is not covered by this legislation, Schneider Electric is willingly attempting to optimise the recycling, the processing of waste and, as a consequence, the end of service life phase of our products, which is an integral part of the operating costs.



PE9548



Release valve

## At the end of the FBX service life

The dismantling and disassembly of FBX is possible at the end of its service life. The separation of the elements making up the switchgear will be made:

- Either by disconnecting the mechanical connections
- Or, by dismantling, that is to say, by breaking or shearing the connections.

To guarantee efficient and ecological sorting and destruction of the materials, all plastic components have been identified.

- A description of the materials is supplied to customers
- Information on the valorisation process that are supplied to companies in charge of the recycling.

## End of service life processing

Schneider Electric can help you in your FBX end of service life processing approach.

## SF6 gas recovery

The volume of the insulating gas used in FBX is equivalent to 0.5% of the total weight of the switchboard. At the end of the switchboard's service life, gas can be evacuated via the valve to be recycled thanks to a process developed by gas suppliers.

## Composition of materials and valorisation at end of service life

After disassembly (or dismantling), the recovered elements must be forwarded for treatment in the following manner:

### Waste processing

Type of waste	Destination	Recommended processing
SF6 gas	Supplier	Recovery, storage and regeneration
Steel & stainless steel	Local recovery agent	Shredding, sorting and recycling
Non-ferrous metals	Local recovery agent	Shredding, sorting and recycling
Epoxy resin	Cement plant	Revalorisation at a lower added value
Thermoplastics	Local recovery agent	Incineration
Molecular sieve	Authorised network	Elimination
Soiled protective equipment	Authorised network	Incineration
Cables	Local recovery agent	Separation of sheathing and conductors





---

**Schneider Electric**

35, rue Joseph Monier  
CS30323  
F-92505 Rueil-Malmaison cedex (France)

RCS Nanterre 954 503 439  
Share capital: 928,298,512€  
[www.schneider-electric.com](http://www.schneider-electric.com)

NRJED311061EN



*This document has been printed  
on ecological paper*



Design: SYNTHÈSE ECA, Schneider Electric  
Photos: Schneider Electric

06-2015